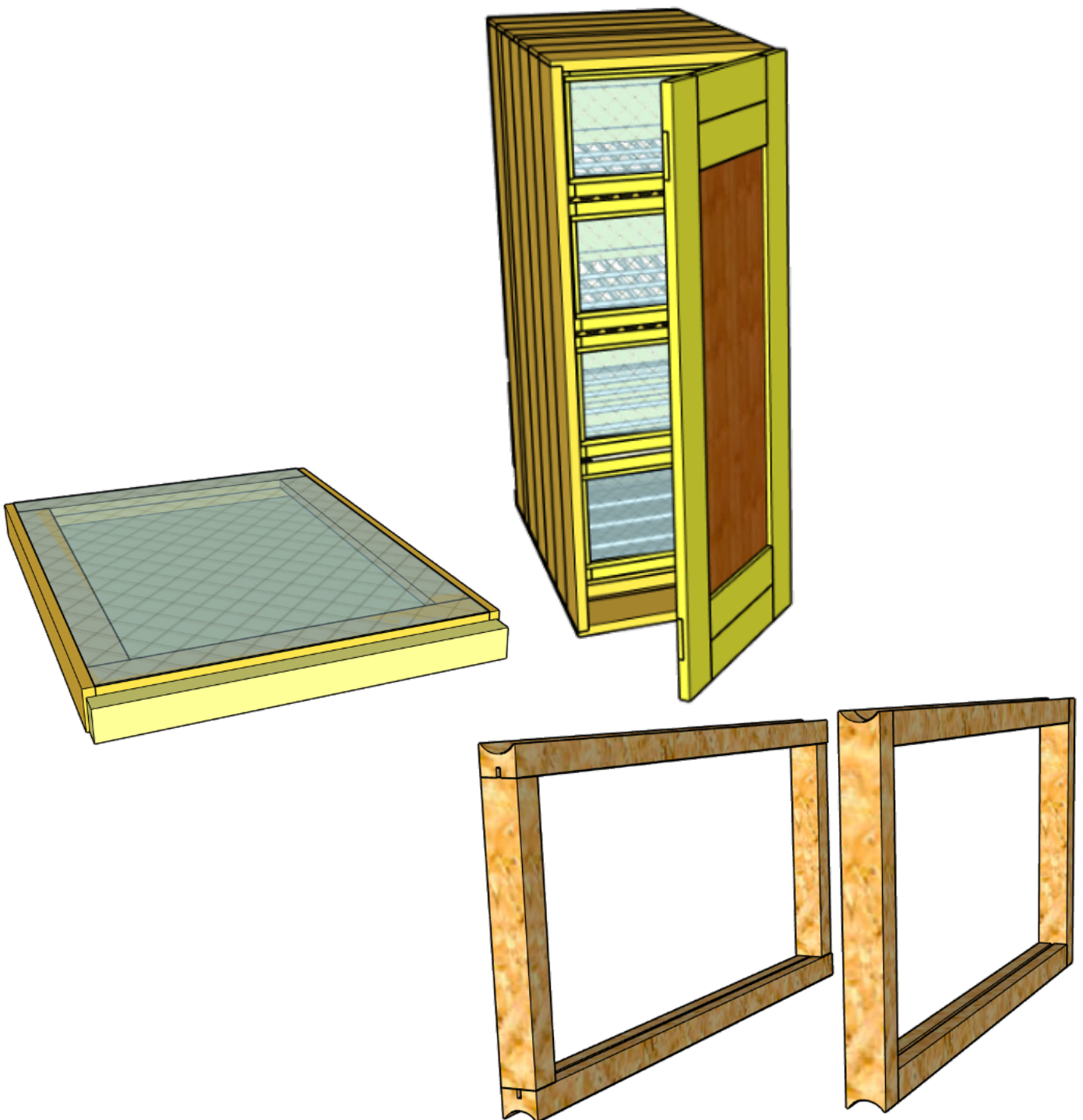


# AZ-Hive

## 4-level



# Forward

This document has been created with the best intentions to serve as a comprehensive guide for constructing an AZ beehive. As it stands, this is a theoretical outline, and some inaccuracies may exist. The ultimate goal is to manufacture all the parts described here and verify the measurements. To assist with this, I will also be producing a YouTube series documenting the build process and providing additional instructions for constructing this type of beehive.

## Structure of the Document

The document is divided into two main sections:

1. **Common Parts:** Descriptions of components that are universal to all types of AZ beehives.
2. **Hive-Specific Parts:** Details and instructions unique to specific hive variations.

This structure aims to simplify navigation and make it easier to locate relevant information for your specific project.

## Supporting This Project

If you find these plans useful and wish to support the effort, you are welcome to contribute a small amount via PayPal to **thomas.arnesen@tega.se**. However, please note that this document is entirely free to use, and contributions are not required.

## Sharing and Updates

As the document is expected to evolve over time, please use and share the link to the original document to ensure you are accessing the latest version.

The original and most updated document can be downloaded at

<https://www.biportalen.se/>

Updates	4
AZ Hive	5
Introduction	5
Safety Precautions	5
Materials Needed	5
What We Will Build	5
Tools Needed	6
Frames	7
Why Adapt to Langstroth?	7
Materials and Precision	7
AZ Frame Dimensions and Assembly	7
Internal Separators	10
Queen Excluder	10
Building the Frame	10
Bee Space Divider	13
Purpose	13
Materials	13
Assembly Instructions	15
Bottom inner floor	16
Varroa floor	16
Roof and bottom	25
Inner door normal	27
Inner wall	33
Front wall	33
Isolation	34
AZ-Hive 4 levels	36
Side boards	36
First front board	36
Second board	37
Board with slots for the rods	38
Back door	39
Materials for the Back Door Frame:	39
Assembly	47

## Updates

Date	What
2024-12-29	A mixup of measurements for the size of the bars of the frames. Thanks to M Walters

## AZ Hive

### Introduction

This document aims to help anyone build an AZ Hive in a home workshop. While advanced tools like a table saw and a planer/moulder can simplify the process, they are not mandatory. Precision is key—small errors early on can become significant issues later.

The AZ Hive is designed for easy management and maintenance, making it ideal for beginner beekeepers. Its design minimizes disturbance to the bees, promoting healthier and more productive colonies. The hive is meant to be placed in a bee house, helping regulate temperature and allowing inspections in almost any weather. There's no need for heavy lifting once the hive is installed, and if housed in a bee house, you only need to paint the front.

This guide walks you through building an AZ Hive using basic woodworking tools and materials. While Langstroth frame dimensions are used here for compatibility with common equipment like honey extractors, the hive can be adapted to other frame sizes.

### Safety Precautions

Working with woodworking tools can be dangerous. Prioritize safety by following these precautions:

1. **Wear Protective Gear:** Use safety goggles, a dust mask, and gloves that fit properly to avoid injuries.
2. **Keep Your Workspace Clean:** An organized, clutter-free workspace reduces risks.
3. **Use Tools Correctly:** Read tool manuals and avoid bypassing safety features.
4. **Maintain Tools:** Keep tools sharp and well-maintained.
5. **Ensure Electrical Safety:** Use grounded outlets and check for frayed cords.
6. **Ventilate Properly:** Work in a well-ventilated area to avoid inhaling dust or fumes.
7. **Secure Your Workpiece:** Use clamps or vices to hold materials firmly.
8. **Take Breaks:** Rest regularly to stay alert.
9. **Keep a First Aid Kit Handy:** Be prepared for minor injuries.
10. **Stay Focused:** Avoid distractions and impaired work conditions.

### Materials Needed

- Lumber
- Nails and screws
- Queen excluder net
- Net for inner doors
- Wood glue
- Hinges
- 8 mm metal rods
- Frame spacers

### What We Will Build

- Four types of AZ Hives
- Queen excluder

- Level dividers
- Inner and outer doors
- AZ frames (Langstroth dimensions)
- AZ frames (400 mm high)
- Varroa bottom

## Tools Needed

### MINIMUM:

- Saw
- Router
- Drill
- Metal saw
- Hammer
- Speed square
- Screwdriver
- Measuring tape
- Sandpaper

### GOOD TO HAVE:

- **Miter Saw:** For faster and more precise cuts.
- **Planer:** To avoid needing pre-planed lumber.
- **Jointer:** For perfect 90-degree joints.
- **Drill Press:** For precise drilling.

### LUXURY:

- **2 or 4-Sided Moulder:** Invaluable for bee frame rabbets and dimensioning boards. However, it's unnecessary if only used for this project.

## Frames

In this description, I adapt the frames to Langstroth size.

### Why Adapt to Langstroth?

The reason is simple: many beekeepers already own equipment designed for Langstroth frames, so it makes sense to use the same dimensions. If you prefer a different frame size, you can adjust the measurements to fit your preferred frame size, as long as you adapt the AZ Hive dimensions accordingly.

### Materials and Precision

To create the frames, I use planed lumber. This ensures precise measurements and gives a cleaner finish. However, using planed lumber is not strictly necessary if you have other tools to achieve accurate dimensions.

### AZ Frame Dimensions and Assembly

An AZ frame has the following outer dimensions: **448 mm long** and **232 mm high**. You can choose between different assembly methods for the frames. I prefer the method shown on the left in **Figure 1**, as it simplifies the manufacturing of profiled boards.

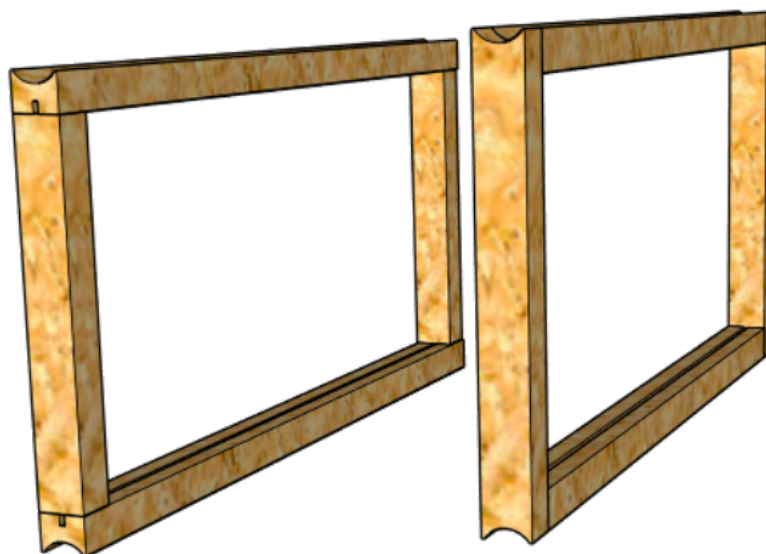


FIGURE 1

## TOP AND BOTTOM BARS

- **Left Assembly:** For the assembly method on the left, the top and bottom bars should be:
  - **448 mm long**
  - **20 mm high**
  - **25 mm wide**
- **Right Assembly:** For the assembly method on the right, the top and bottom bars should be:
  - **408 mm long**
  - **20 mm high**
  - **25 mm wide**

The groove for the wax foundation is **3 mm wide** and **6 mm deep**. This groove can be made using a table saw, for example. The U-shaped groove on the top and bottom can be created with a router. While I use a multi-headed planer to shape the top and bottom bars before cutting them to length with a miter saw, this method may not be accessible to everyone.

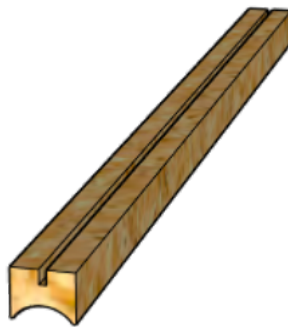


Figure 2

## SIDE BARS

The side bars should always be:

- **25 mm wide**
- **20 mm thick**

### Short Side Bars

If you mount the top bar **on the end** of the side bars, the side bars should be:



- **192 mm long**  
Se **Figure 2**.

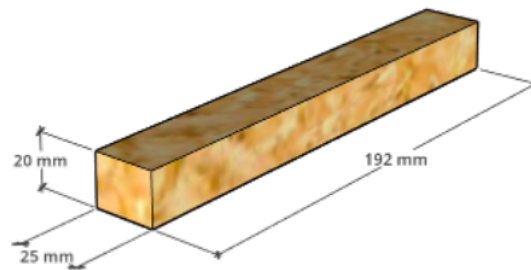


Figure 3

### Long Side Bars

If you mount the top bar **on the side** of the side bars, the side bars should be:

- **232 mm long**  
Se **Figure 3**.

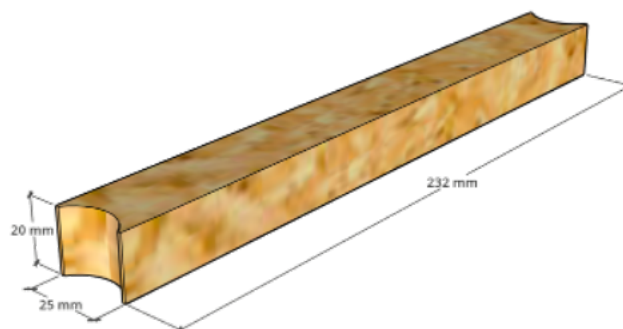


Figure 4

For the long side bar assembly, I recommend planing a board down to **25 mm**, cutting it to the appropriate length, creating the groove on the end with a router, and then cutting the boards into **20 mm wide** pieces.

## Internal Separators

### Queen Excluder

The queen excluder is a crucial component of the hive, as it prevents the queen from accessing specific areas while allowing worker bees to move freely. This is essential for managing brood and honey storage. For your hive, you will need both **queen excluders** and **bee space dividers**.

#### CHOOSING THE MATERIAL

Queen excluders are available in metal, plastic, or wood. While plastic and wood are cheaper, I prefer **metal excluders** due to their durability and the belief that they are better for the bees. This guide is tailored for metal queen excluders.

### Building the Frame

To create the frame for the queen excluder, you will need the following boards:

- **2 pieces:** 10 mm x 45 mm x 372 mm
- **2 pieces:** 10 mm x 45 mm x 485 mm

(See *Figure 5* for board dimensions.)

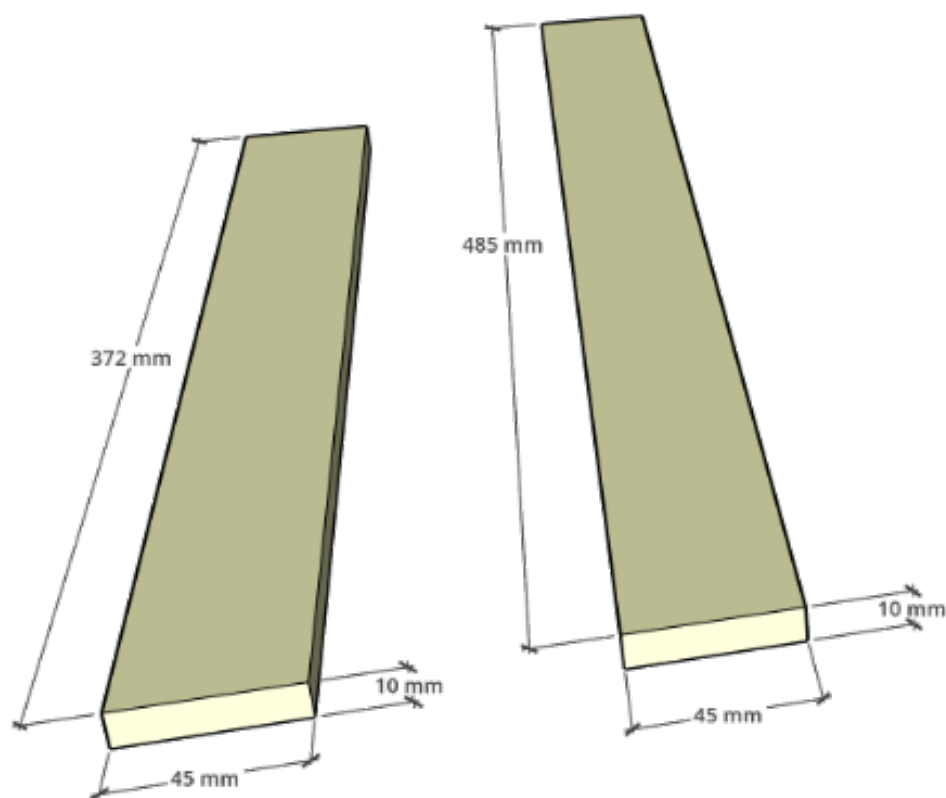


Figure 5

## PREPARING THE BOARDS

At both ends of the boards, create a rabbet that is **5 mm deep** and **45 mm wide** using a router.

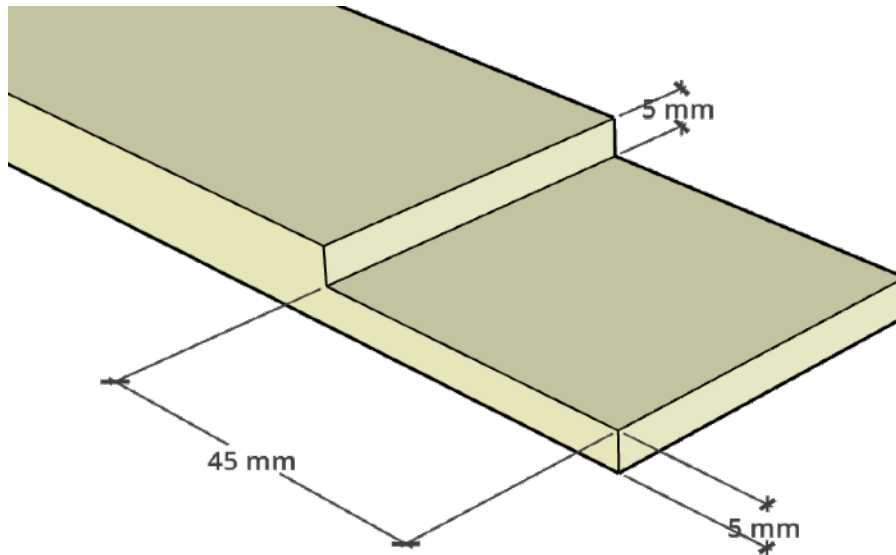


Figure 6

*Create a groove along the inside, 10mm deep and 3mm wide to place the queen exclude gitter.*

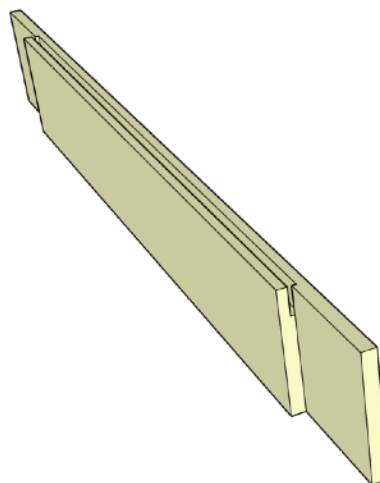


Figure 7

### ASSEMBLING THE FRAME

1. Glue the boards together to form the frame. Ensure that the rabbets align properly.
2. Fit a metal queen excluder into the assembled frame. You will need one queen excluder per hive.

(See **Figure 6** for the assembled frame with the queen excluder.)



Figure 8

## Bee Space Divider

### Purpose

The bee space divider is essential for maintaining the correct bee space between levels that do not have a queen excluder. It also provides a resting place for the inner door, preventing the bee space from becoming too large.

(See **Figure 9** for an illustration of the bee space divider.)

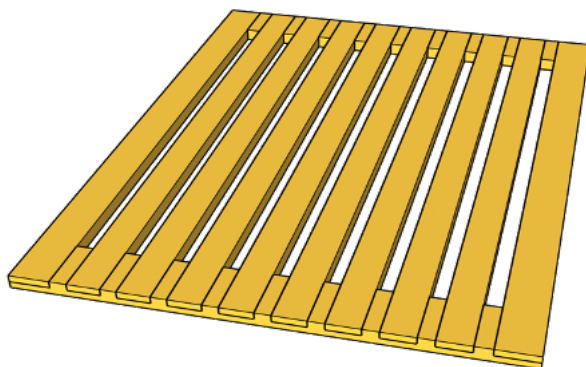


Figure 9

### Materials

You will need the following components to construct the divider:

1. **Left and Right Long Boards** (2 pieces)
  - These boards form the outer edges of the divider.

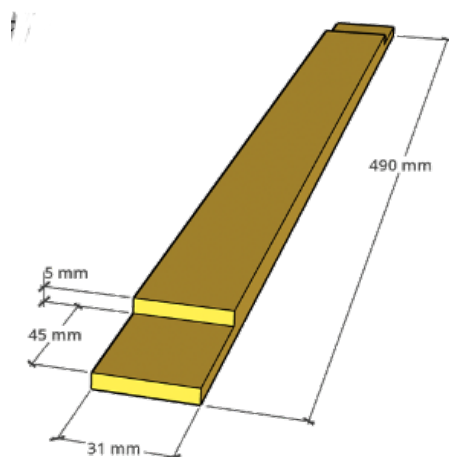


Figure 10

2. **Inner Long Boards** (8 pieces)

- These boards are placed parallel to one another between the left and right long boards.

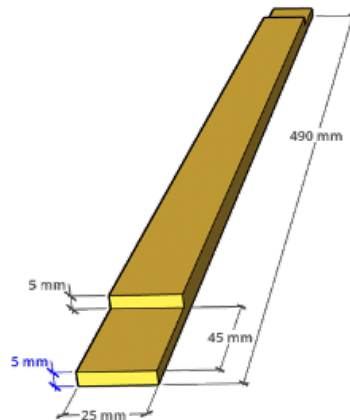


Figure 11

3. **End Boards** (2 pieces)

- These hold the entire structure together at both ends.

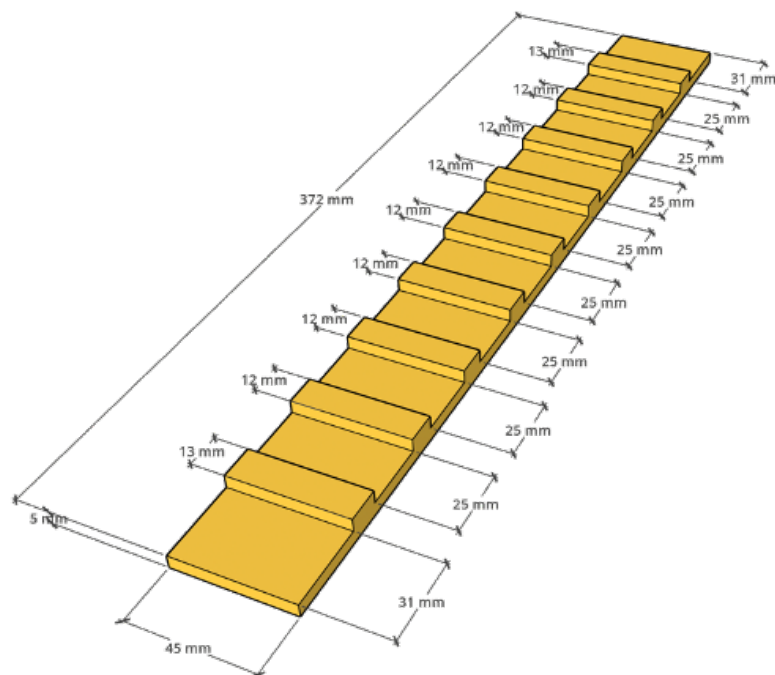


Figure 12

## Assembly Instructions

### PREPARING THE BOARDS

- Create slots in the long and end boards to hold the inner boards.
- Slots can be made using a router or a table saw equipped with a dado stack.
- **Safety Note:** These boards are thin, so exercise caution to avoid accidental contact with rotating tools.

### ASSEMBLING THE DIVIDER

1. Apply wood glue to the slots in the left and right long boards.
2. Insert the inner boards into the slots, ensuring they are evenly spaced.
3. Attach the end boards to secure the structure.
4. Allow the glue to dry completely before using the divider.



Figure 13

## Bottom inner floor

### Varroa floor

Varroa, specifically *Varroa destructor*, is a parasitic mite that primarily affects honeybees (*Apis mellifera*). This tiny arachnid is a major threat to bee populations worldwide and is often referred to as the Varroa mite. The varroa floor is designed to help monitor and manage mite infestations by providing a way to observe the mite population within the hive, allowing timely treatment when necessary. To build the varroa floor, you will need the following components:

- Start by creating a planed sideboard that is 490 mm long, 38 mm wide, and 20 mm thick.

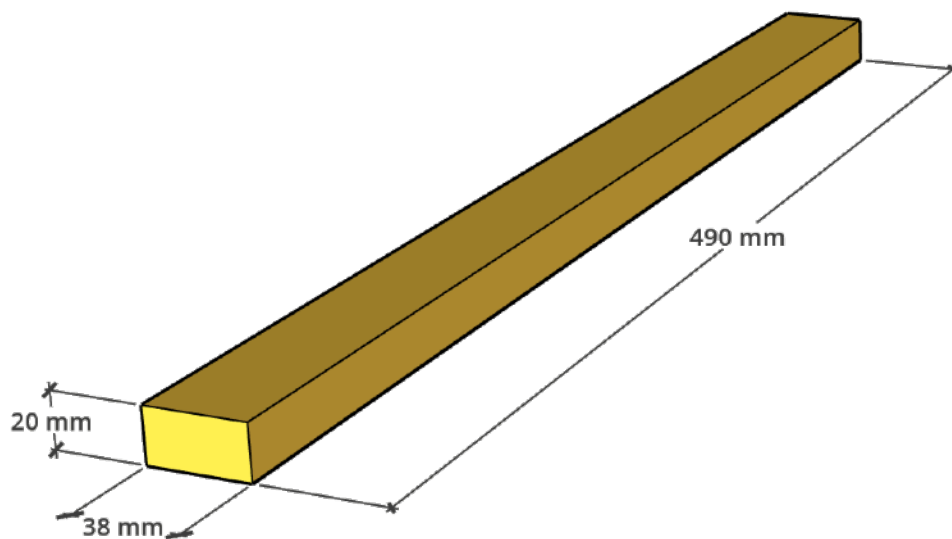
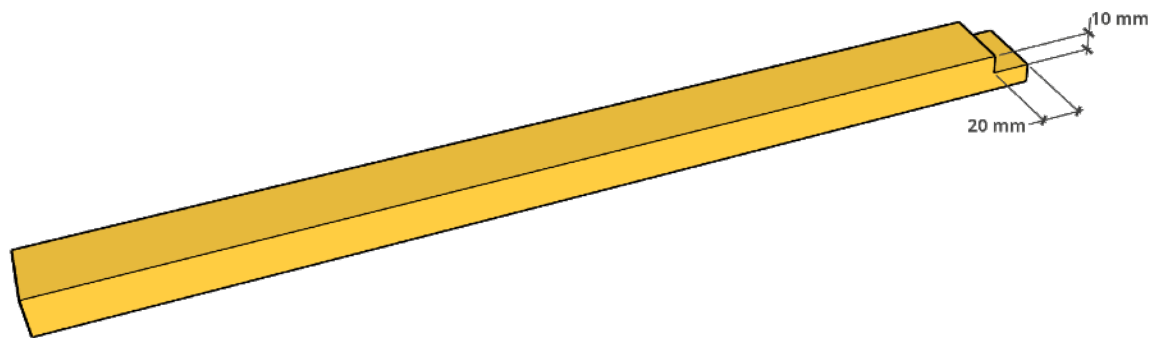


Figure 14 planed sideboard

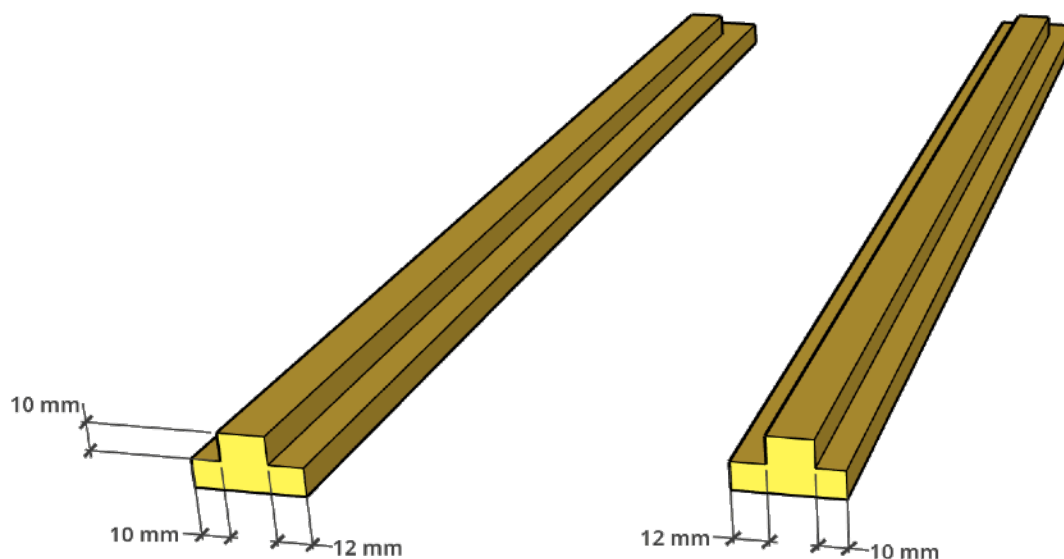
- Make a 20 mm wide and 10 mm deep rabbet at one end of the sideboard.





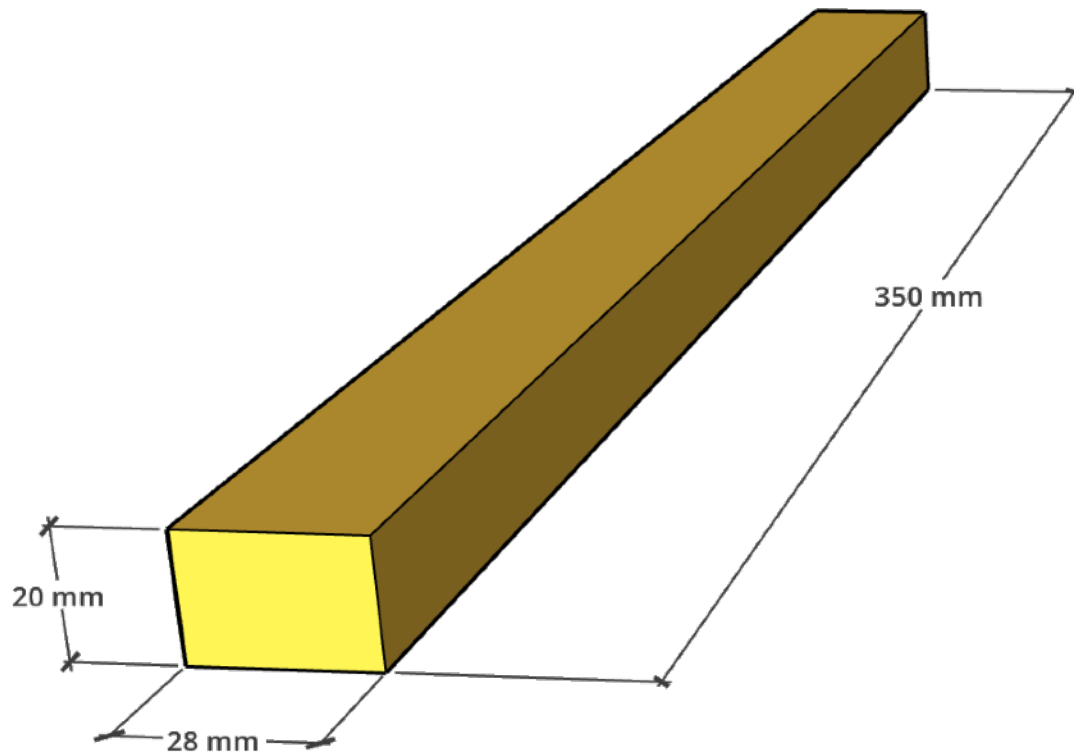
*Figure 15 Side board with end rabbet*

- On each side of the board, create 10 mm deep rabbets. One rabbet should be 10 mm wide and the other 12 mm wide. Note that these rabbets should be mirrored on the left and right board.



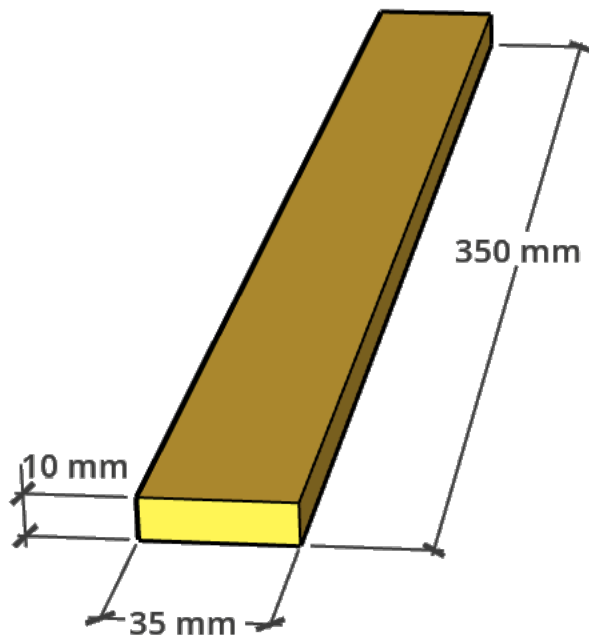
*Figure 16 Side boards with rabbets for top and bottom boards*

- Create a backend board that is 350 mm long, 28 mm wide, and 20 mm high.



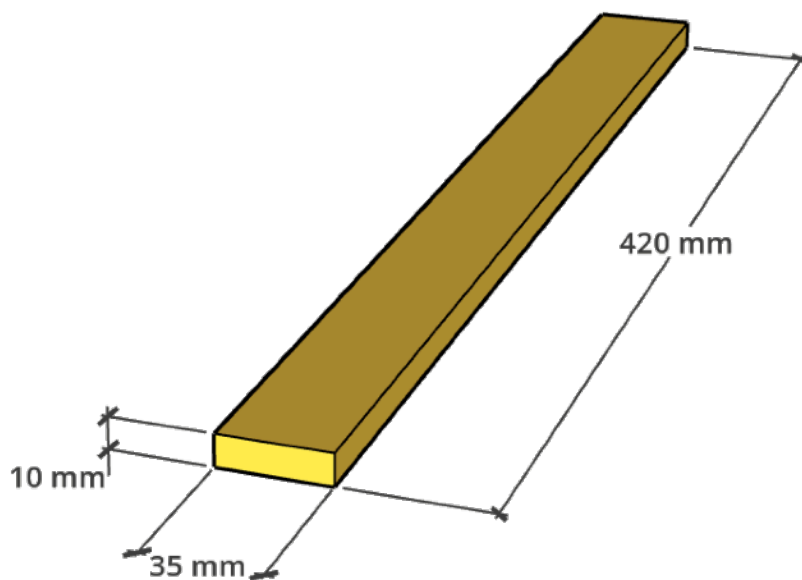
*Figure 17 End board*

- Prepare a short top board that is 350 mm long, 35 mm wide, and 10 mm high to help hold the varroa mesh.



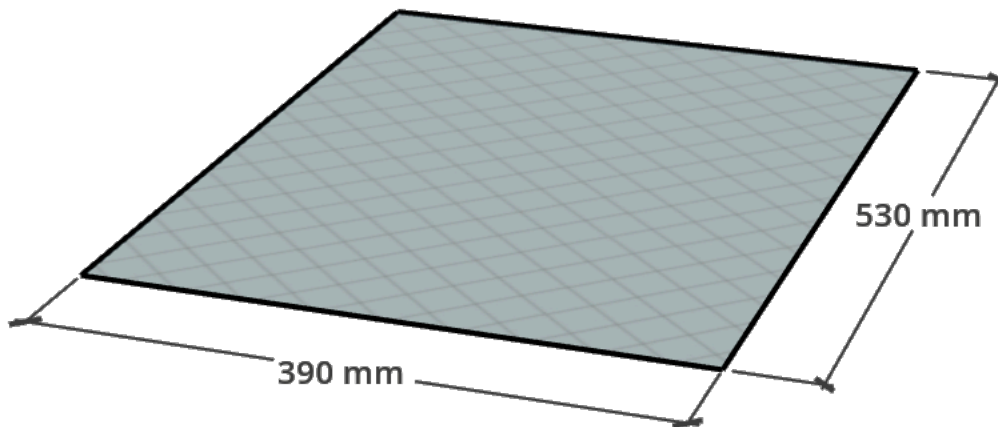
*Figure 18 Short top board*

- Prepare a long top board that is 420 mm long, 35 mm wide, and 10 mm high to hold the varroa mesh.



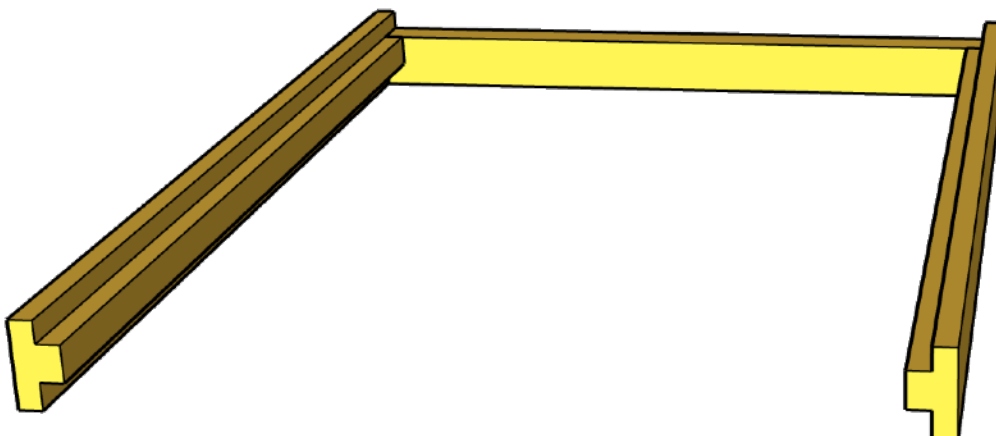
*Figure 19 Long top board*

- Purchase a mesh for the varroa board, with a mesh size of 3-4 mm. Cut it to approximately 390 mm x 530 mm.



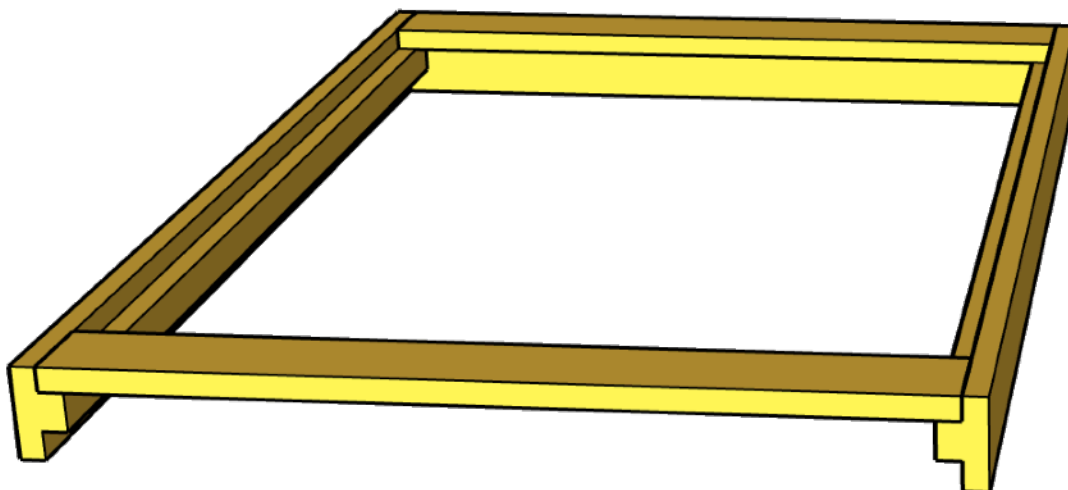
*Figure 20 Mesh*

- Glue and nail the backend board to the sideboards with the 12 mm rabbet positioned at the bottom.

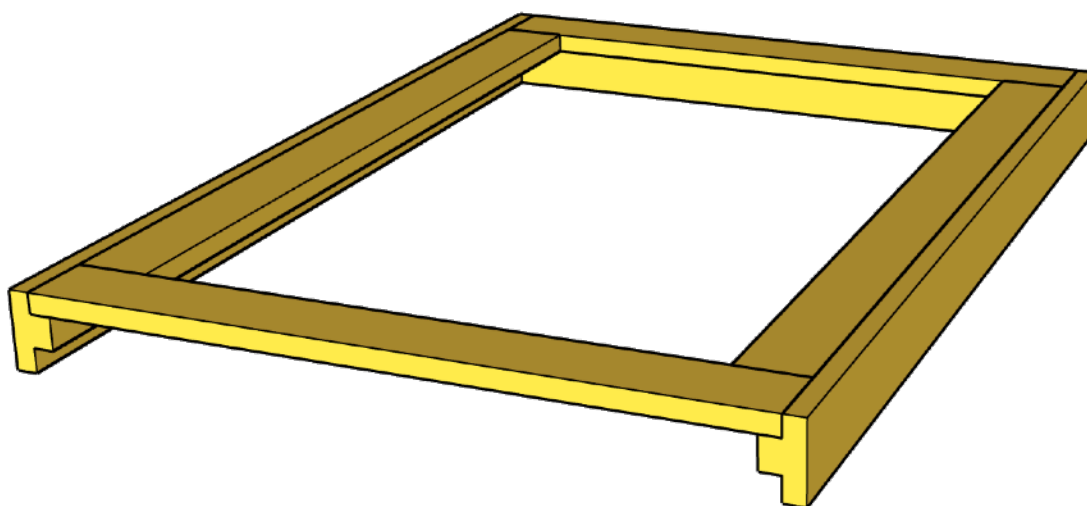


*Figure 21 First assembly, sides and backend*

- Dry fit the top boards without fastening them, as you will need to add the mesh first.

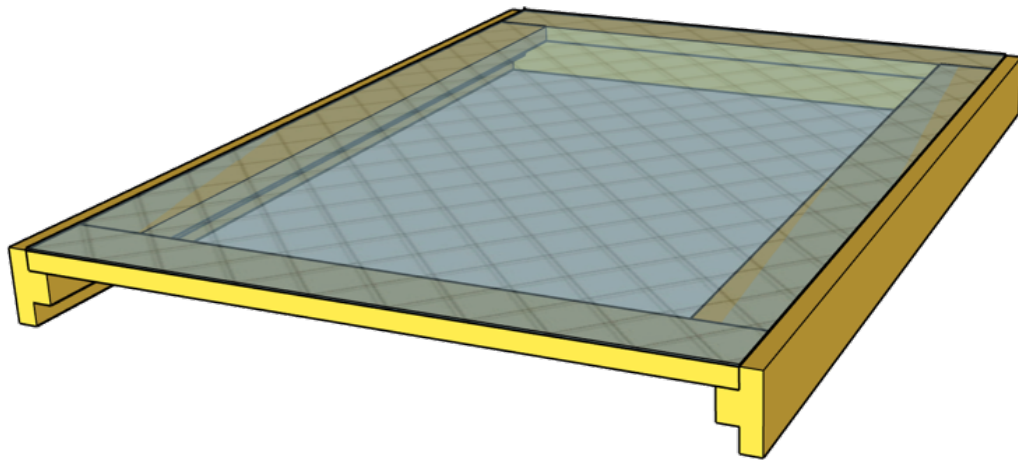


*Figure 22 Dry fit the short top boards*



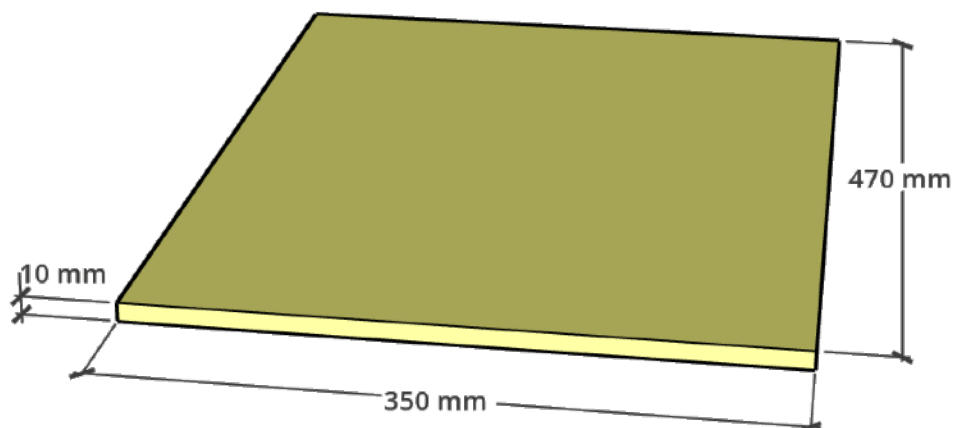
*Figure 23 Dry fit the long top boards*

- Attach the mesh with a 20 mm overlap around the top boards. Start by gluing and nailing one side to provide stability for the mesh.



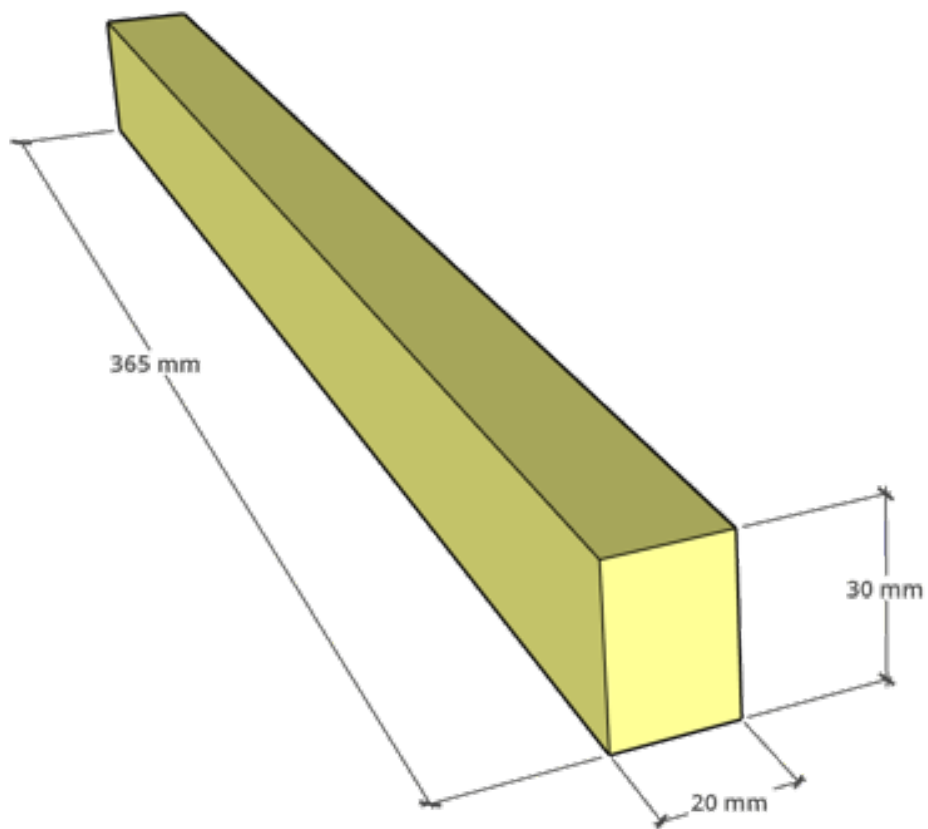
*Figure 24 Varroa bottom with mesh*

- Create the bottom board using 10 mm plywood.



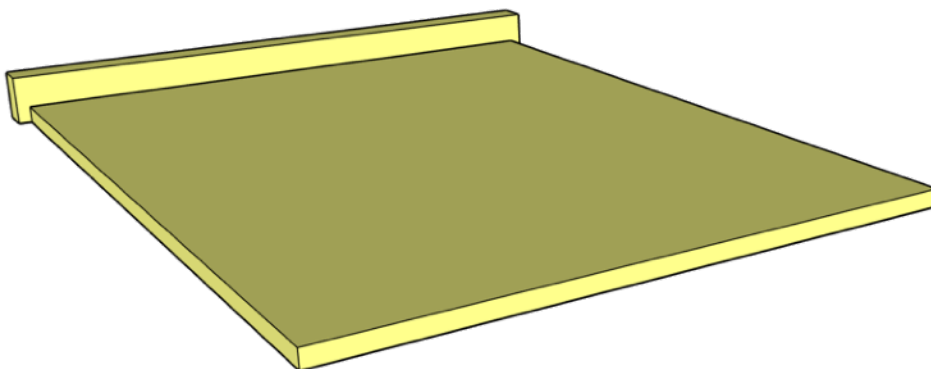
*Figure 25 Bottom board*

- Make a handle for the bottom board. If you prefer, you can add a groove to the handle for a better grip.



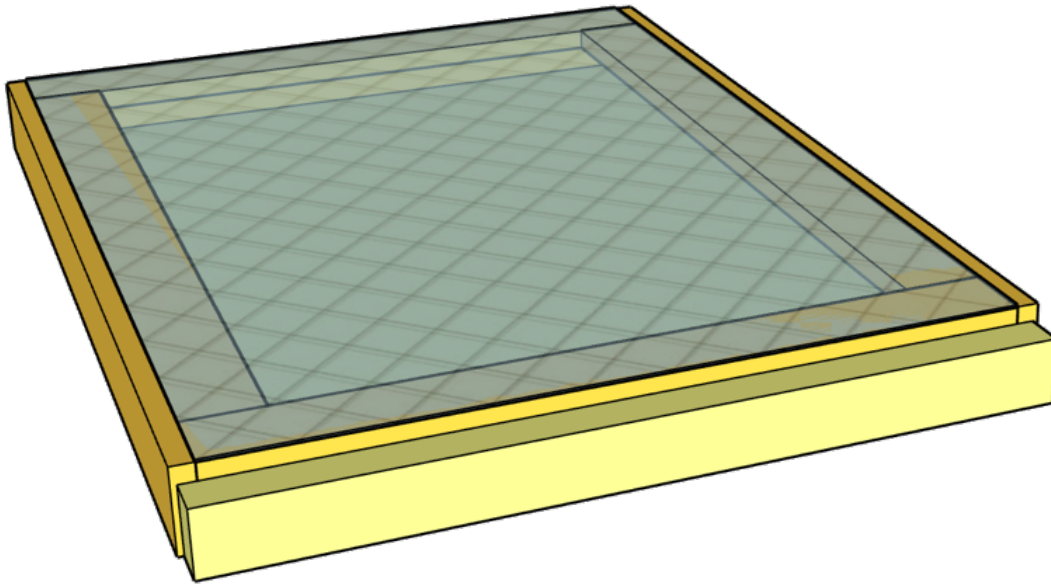
*Figure 26 Handle*

- Glue and screw the handle to the bottom board. Drill pilot holes for the screws to prevent the bottom board from splintering.



*Figure 27 Bottom board with handle*

The end result should look something like this.



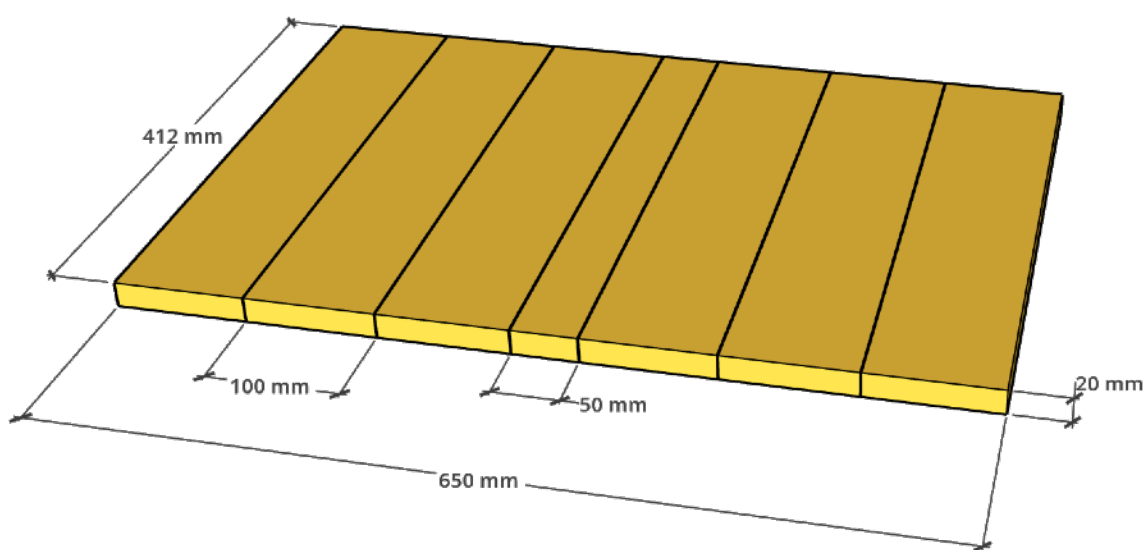
*Figure 28 Varroa floor*



## Roof and bottom

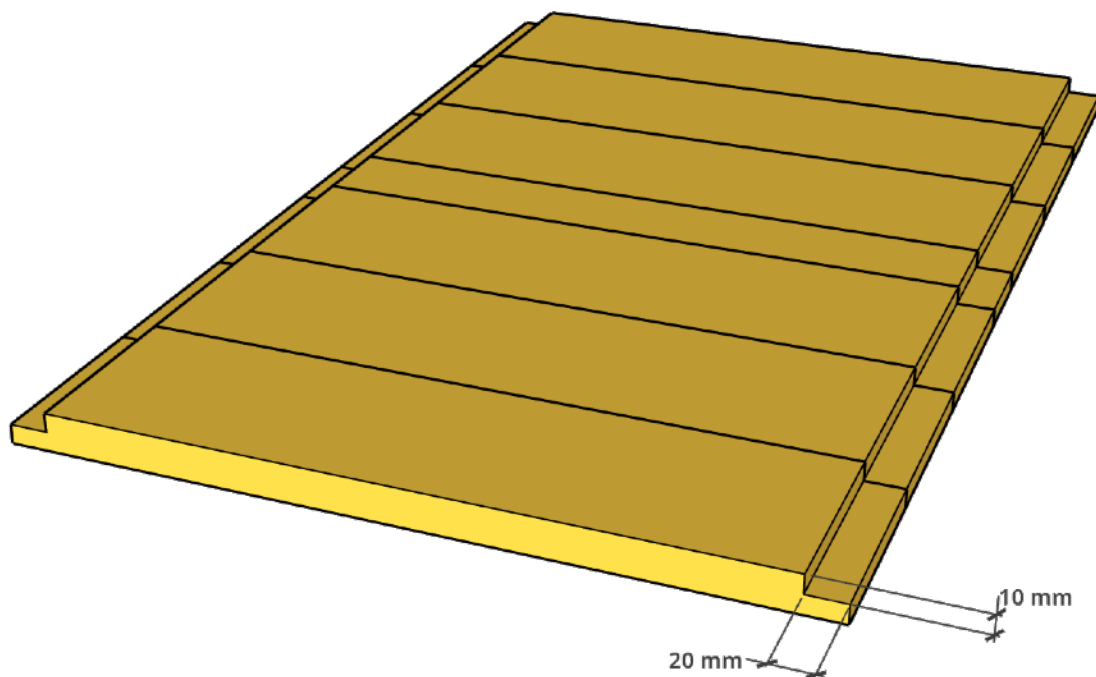
The roof and bottom are identical for all hives described here. You will need six boards, each 100 mm wide, 20 mm thick, and 412 mm long, and one board that is 50 mm wide, 20 mm thick, and 412 mm long.

- 1. Assemble the Panel:** Glue the seven boards together to form a panel measuring 412 mm x 650 mm..



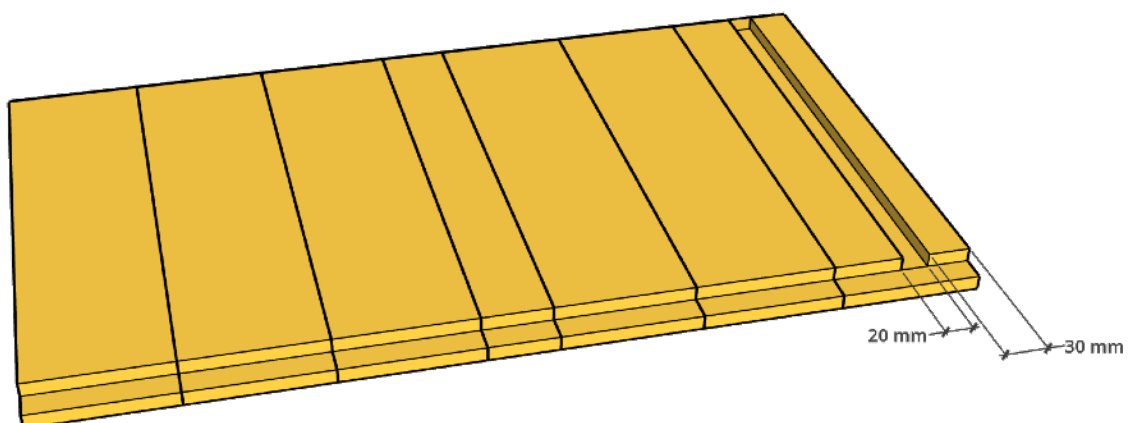
*Figure 26 Roof and bottom*

- 2. Route the Rabbet on the Long Sides:** Using a router, create a rabbet (a recessed groove) that is 20 mm wide and 10 mm deep along both long sides of the panel.



*Figure 27 Roof and bottom with rabbet*

1. **Create the Rabbet for the Inner Wall:** On one of the short sides, create a 20 mm wide rabbet, 10 mm deep, positioned 30 mm in from the edge. This rabbet will accommodate the inner wall of the hive.



*Figure 28 Rabbet for the inner wall*

## Inner door normal

Each level of the hive has an inner door with a screen, allowing you to access each level without significantly disturbing the other levels. This design also enables you to open the back door and inspect the hive without exposing the entire hive to the bees.

The height of each door is 250 mm, and the width is 372 mm. Since wood is a living material, you may need to adjust the size slightly to prevent the door from fitting too tightly and becoming stuck over time.

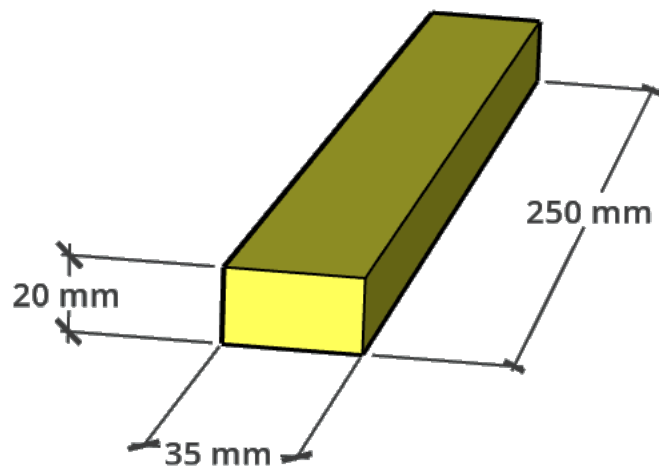
You can use contraprofiles with your router. If you decide to do so, remember to account for the profile depth when creating the door—I learned that the hard way! If you forget, you can hang it up in your workshop as a reminder not to make the same mistake again.

In this guide, we will use the simpler method of half-lap joinery, similar to what we used for the queen excluder.

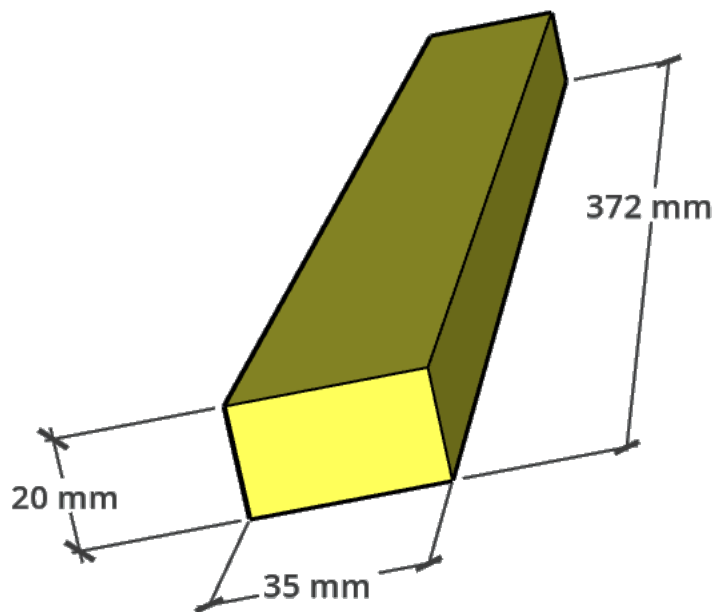
### Materials Needed:

- Two boards: 250 mm x 35 mm x 20 mm
- Two boards: 372 mm x 35 mm x 20 mm
- 1-3 mm metallic mesh

1. **Prepare the Boards:** Rip a board and plane it down to 35 mm x 20 mm, then cut it to the required lengths.

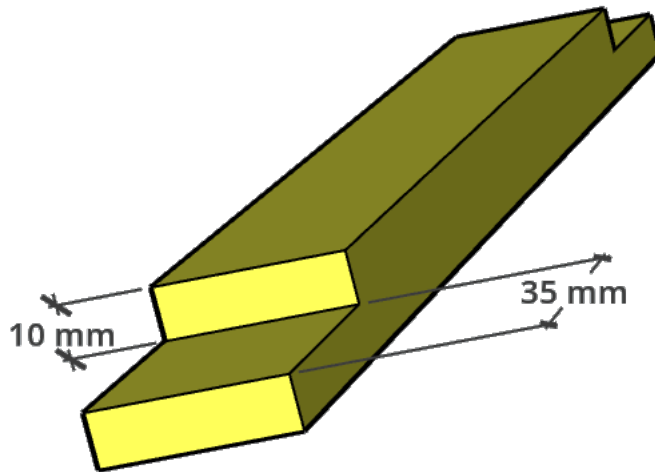


*Figure 29 Side inner door board*



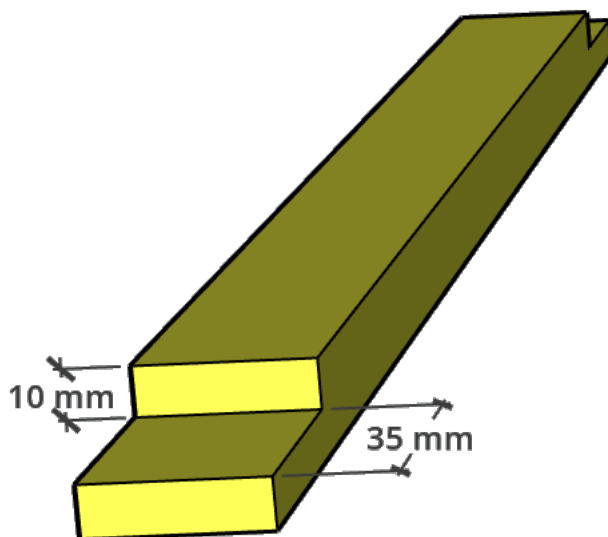
*Figure 30 Top and bottom inner door board*

- 2. Create the Half-Lap Joints:** Route a rabbet on both ends of the short boards.



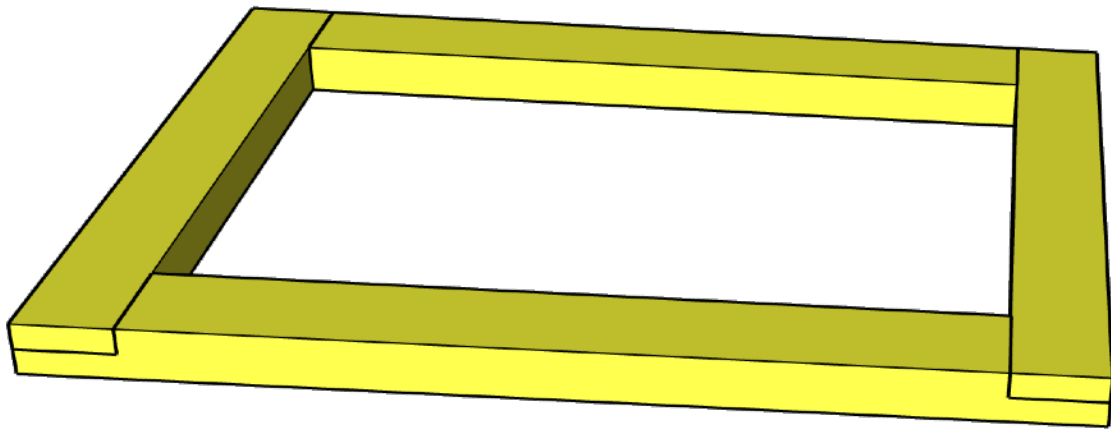
*Figure 31 Side board with cut out for lap joint*

Repeat the process for the long boards.



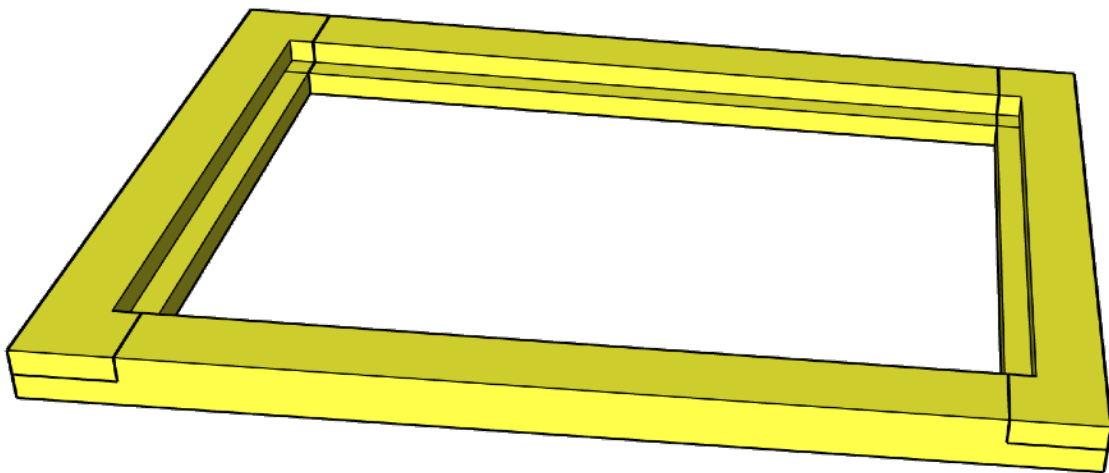
*Figure 32 top and bottom board with cut out for lap joint*

- 3. Assemble the Frame:** Use wood glue to attach the boards, forming a rectangular frame. Measure from corner to corner to ensure the frame is square.



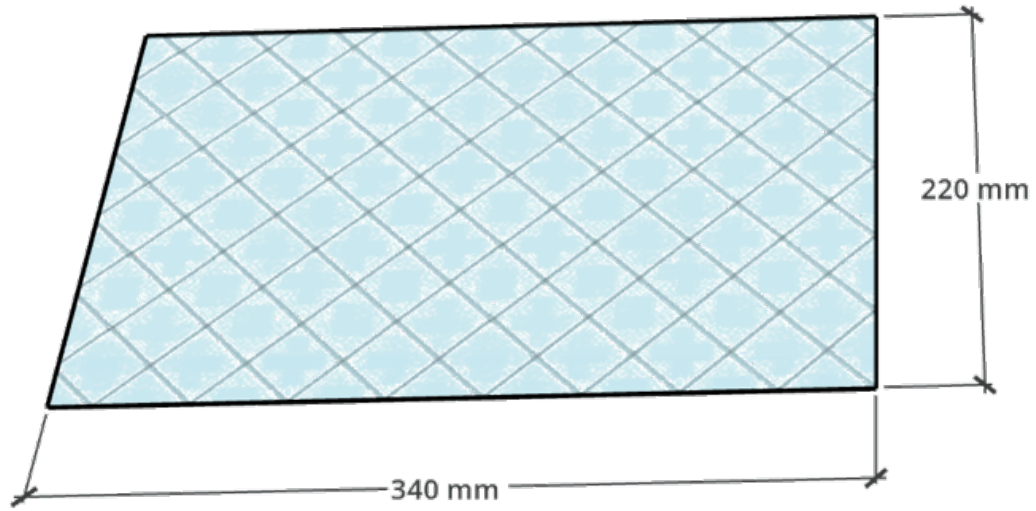
*Figure 33 Assembled inner door frame*

4. **Rout the Rabbet for the Mesh:** With a router, make a rabbet inside the frame that is 10 mm wide and 10 mm deep.



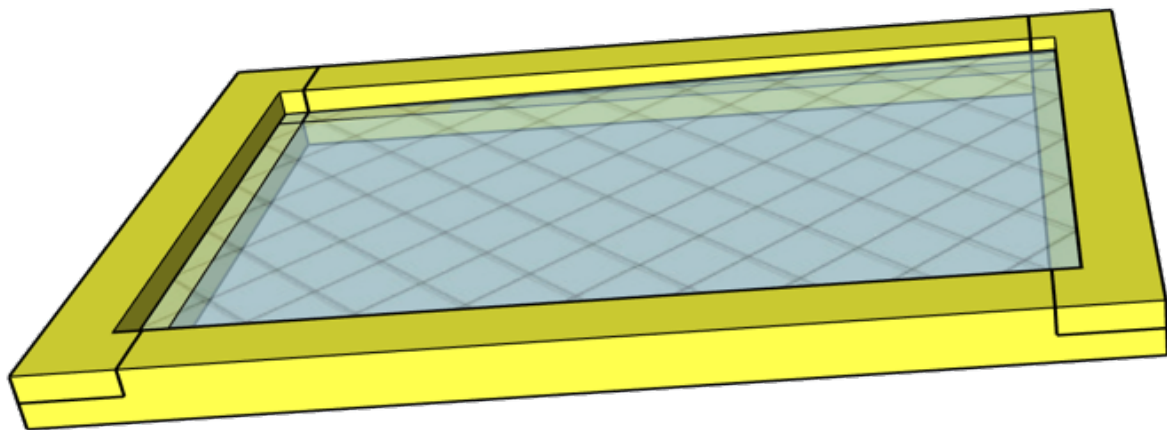
*Figure 34 Rabbet routed for mesh*

5. **Prepare the Mesh:** Cut a metallic mesh to approximately 220 mm x 340 mm, with 1-3 mm holes.



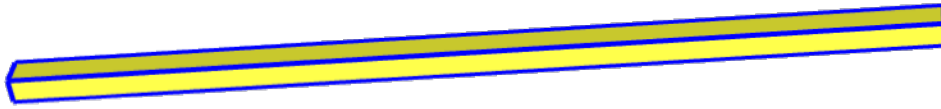
*Figure 35 Mesh*

6. **Attach the Mesh:** Place the mesh on the frame.



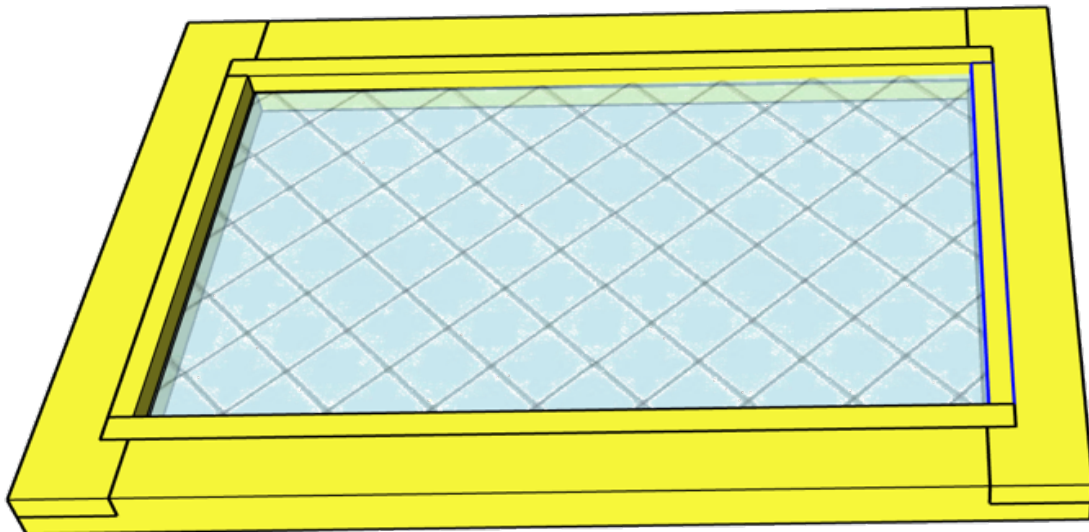
*Figure 36 Mesh placed on the inner door*

Make several 9 mm x 10 mm strips to secure the mesh.



*Figure 37 Fastening board for the mesh*

7. **Secure the Mesh:** Fasten the mesh using glue and the small boards.



*Figure 38 Inner door with fastened mesh*

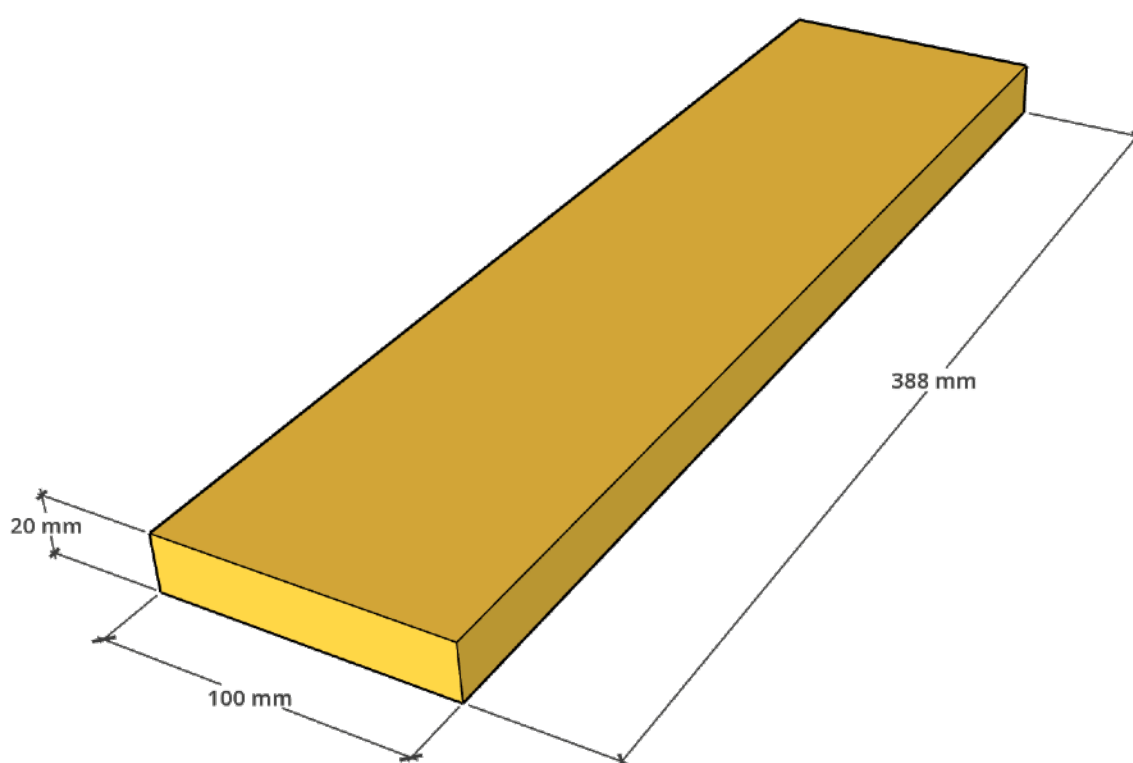
If you wish, you can add a door knob to the door for easier handling.



## Inner wall

For the inner wall, use boards that are 388mm long, 100mm wide, and 20mm thick. These boards will fit into the 20mm x 20mm slots on the side walls.

1. Split some boards as needed to make them fit perfectly.
2. Depending on how exact the slots are and the exact thickness of the board, you might need to trim the thickness fitting in to the slots a bit.

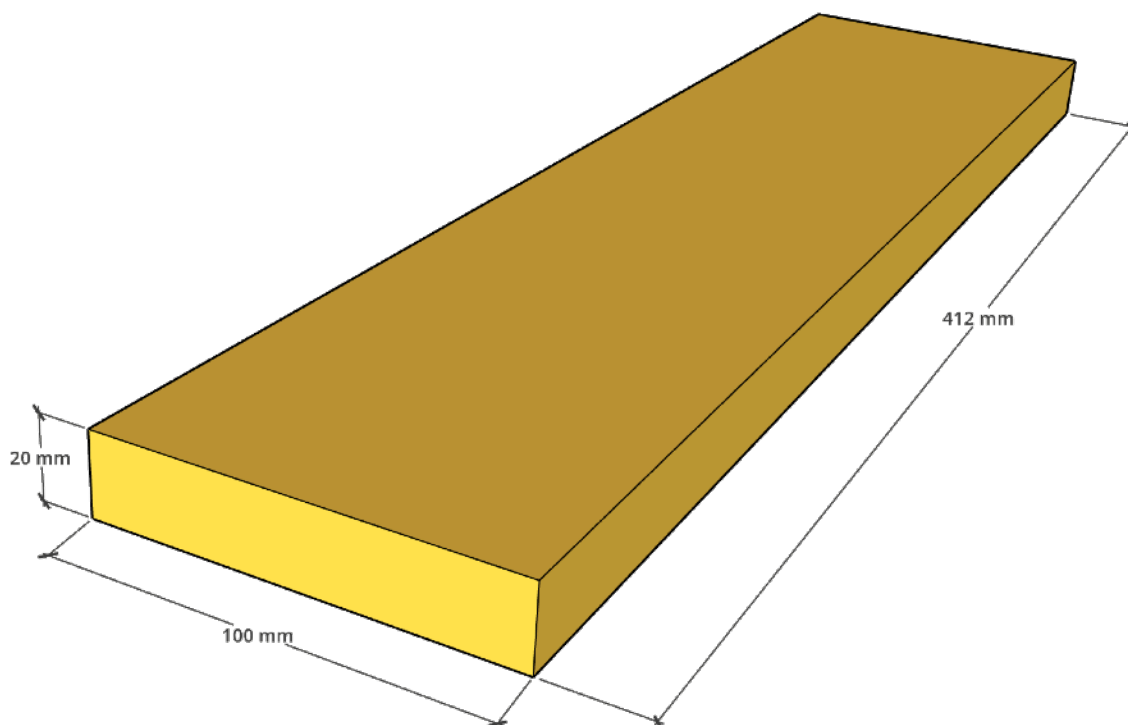


*Figure 39 Inner wall board*

## Front wall

Use boards that are 412mm long, 100mm wide, and 20mm thick for the front wall.

1. Split some boards if necessary to ensure a snug fit.
2. The front wall will support the hive structure.



*Figure 40 Front wall board*

## Isolation

For isolation between the inner and outer walls, use 30mm Stone Wool. This material is preferred because it deters ants and other pests.

1. Cut the Stone Wool to fit snugly between the walls.
2. Add wind protection paper inside the Stone Wool to provide additional insulation for the bees.



*Figure 41 Stone Wool reinforced*



*Figure 42 Wind protection*

## AZ-Hive 4 levels

When it comes to the hive boxes, the height and placement of the rods are the major difference and of course the back door to fit the height.

### Side boards

We need 12 boards, each 100 mm wide, and two approximately 50 mm wide boards. The total height of the side is 1108 mm, which includes an additional 20 mm (10 mm each for the roof and bottom). The depth of the hive is approximately 670 mm, including 20 mm for the front boards. The thickness of all boards is 20 mm.

The lumber used should be 100 mm wide, 20 mm thick, and 1088 mm long. The 50 mm board will be split in two, resulting in two equal boards that are approximately 50 mm wide, likely 48 mm.

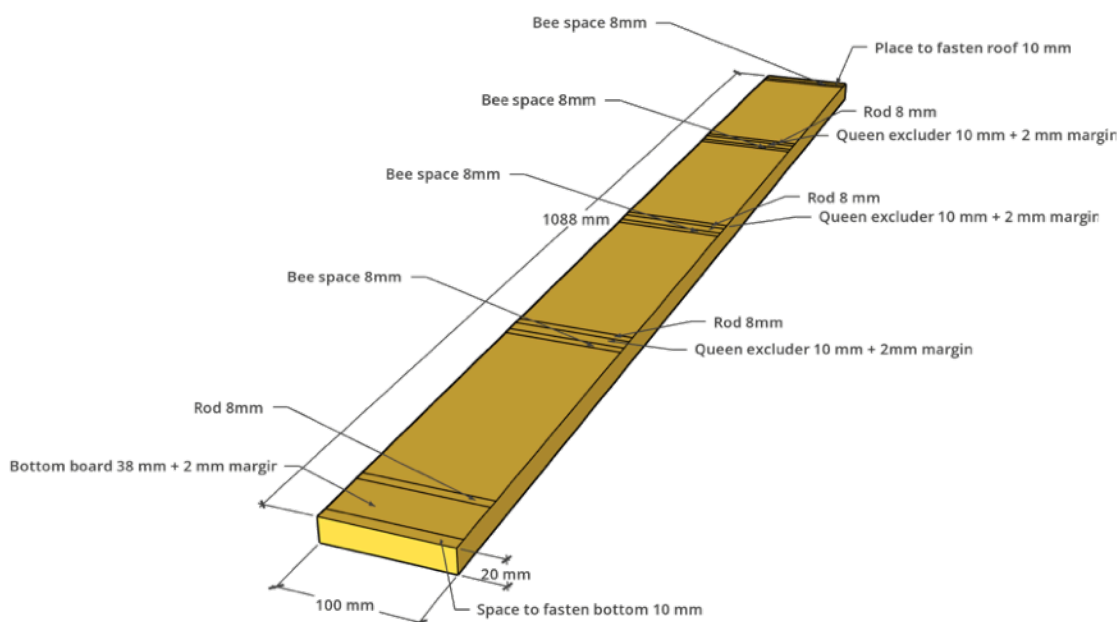
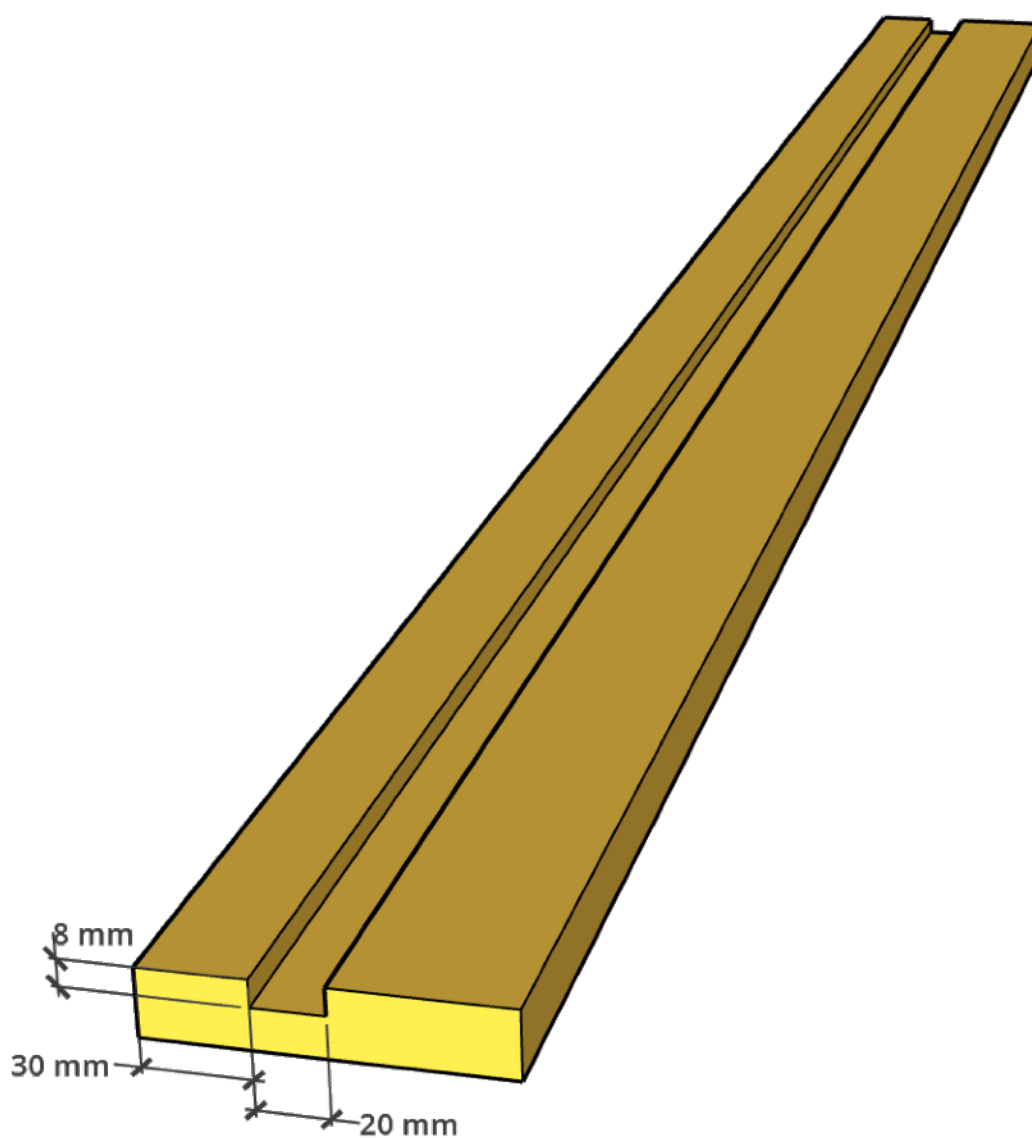


Figure 43 Calculating the side board, not showing the frame heights

### First front board

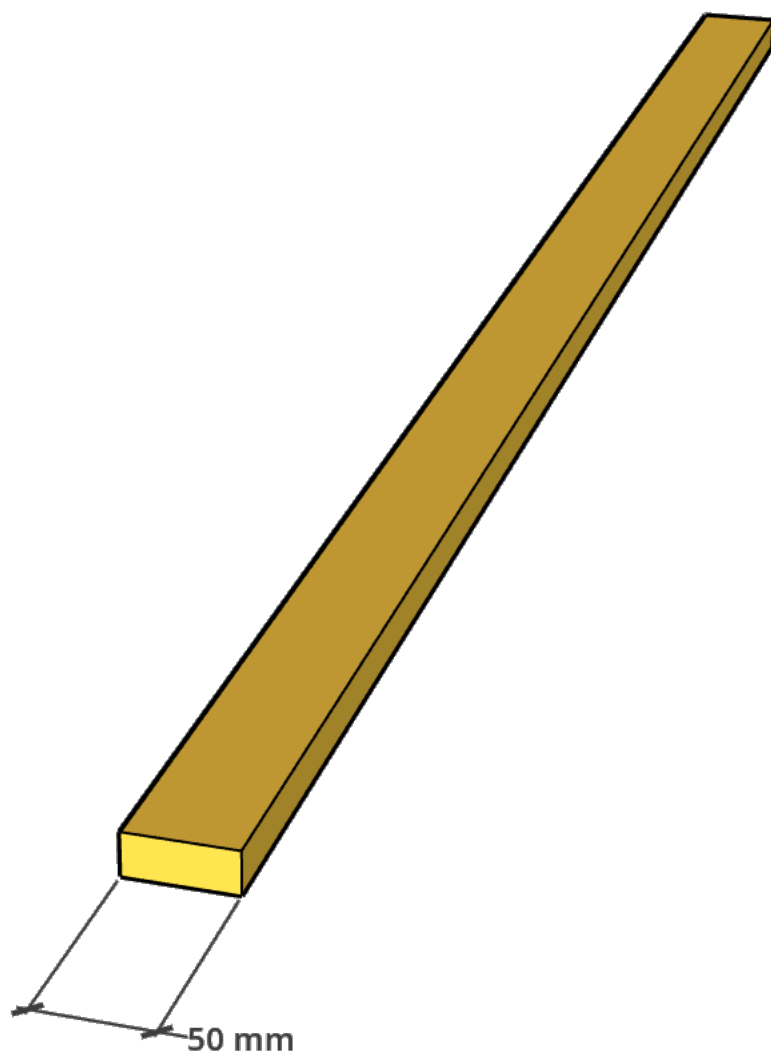
You need two of these boards. On the first side board at the front, route a groove to add the inner wall. A 30 mm space between the inner and outer wall will be filled with insulation.



*Figure 44 First side board to the front*

## Second board

You need two of these. The easiest way is to take one of the 100 mm boards and cut it in half.



*Figure 45 Second board*

### Board with slots for the rods

You will need six of these. Use a router to create slots for the rods. Each slot should be 10 mm wide and 8 mm deep. To allow the rods to be removed and added easily, each slot should be 100 mm long.

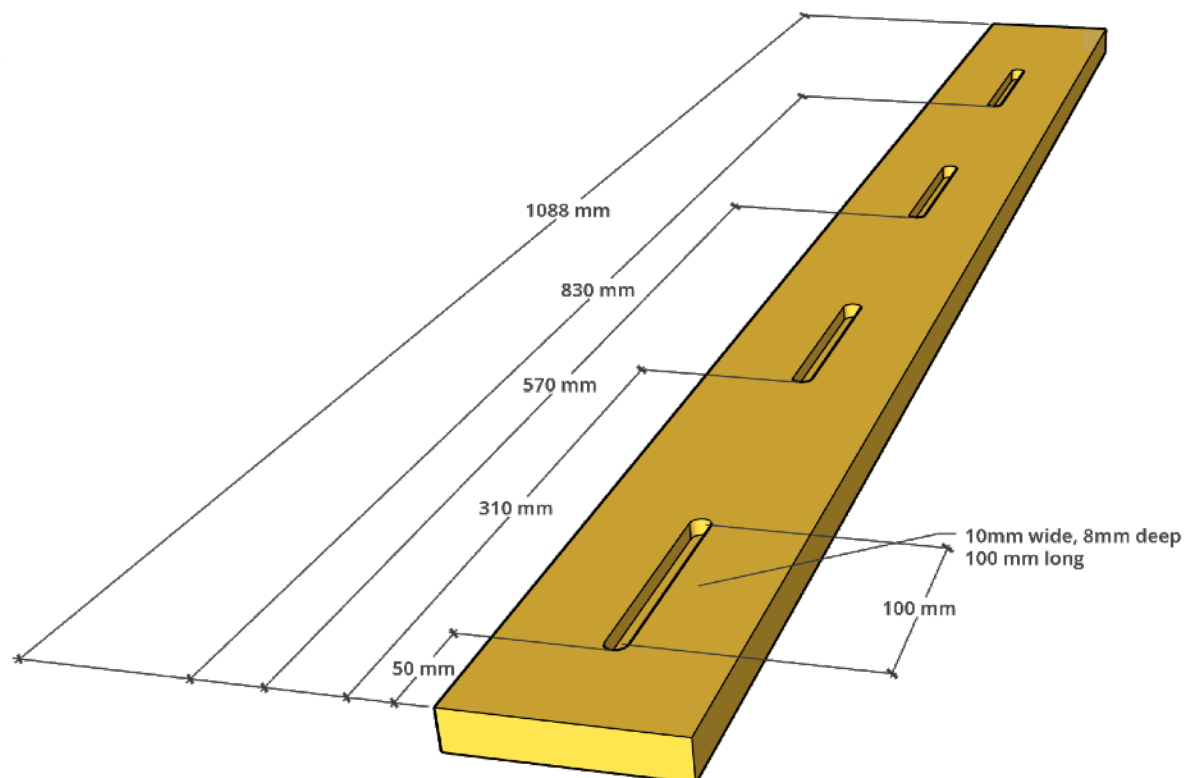


Figure 46 Board with rod slots

## Back door

For the frame of the back door, I prefer to use hardwood like birch, and for the door panel (mirror), birch plywood. This method is simple and effective. While you could use hardwood for the entire door, the approach outlined here is easier and uses hardwood just for the frame.

### Materials for the Back Door Frame:

- **Side Frames:** Two planed boards, each 1108 mm x 80 mm x 20 mm
- **Top and Bottom Frames:** Two planed boards, each 412 mm x 80 mm x 20 mm
- Creating the Rabbets:

- On each end of the short boards (top and bottom frames), create an 80 mm wide and 10 mm deep rabbet.
- On the long boards (side frames), create 80 mm wide rabbets, positioned 80 mm from the end.

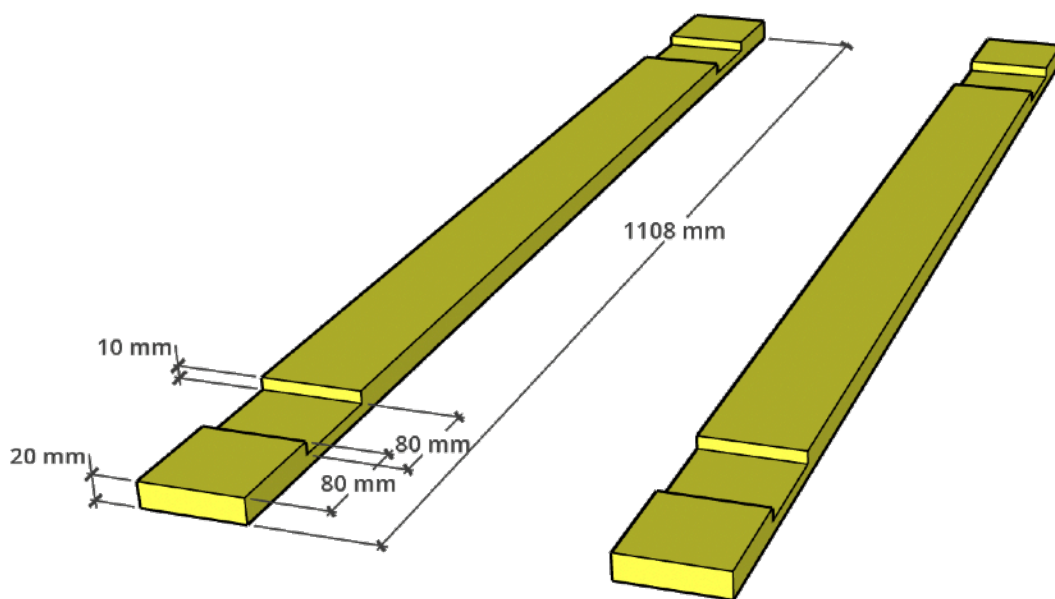
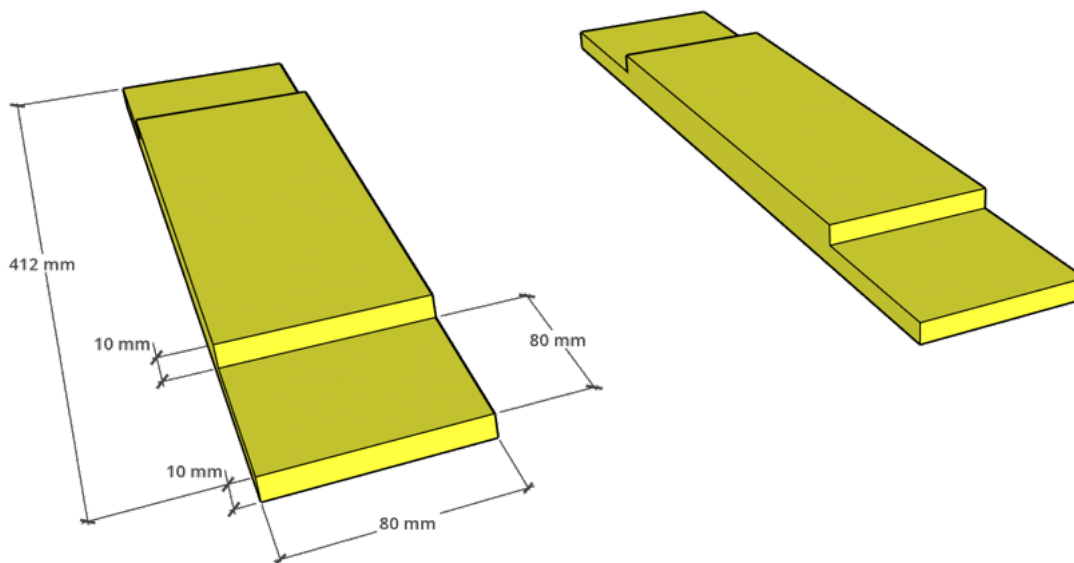


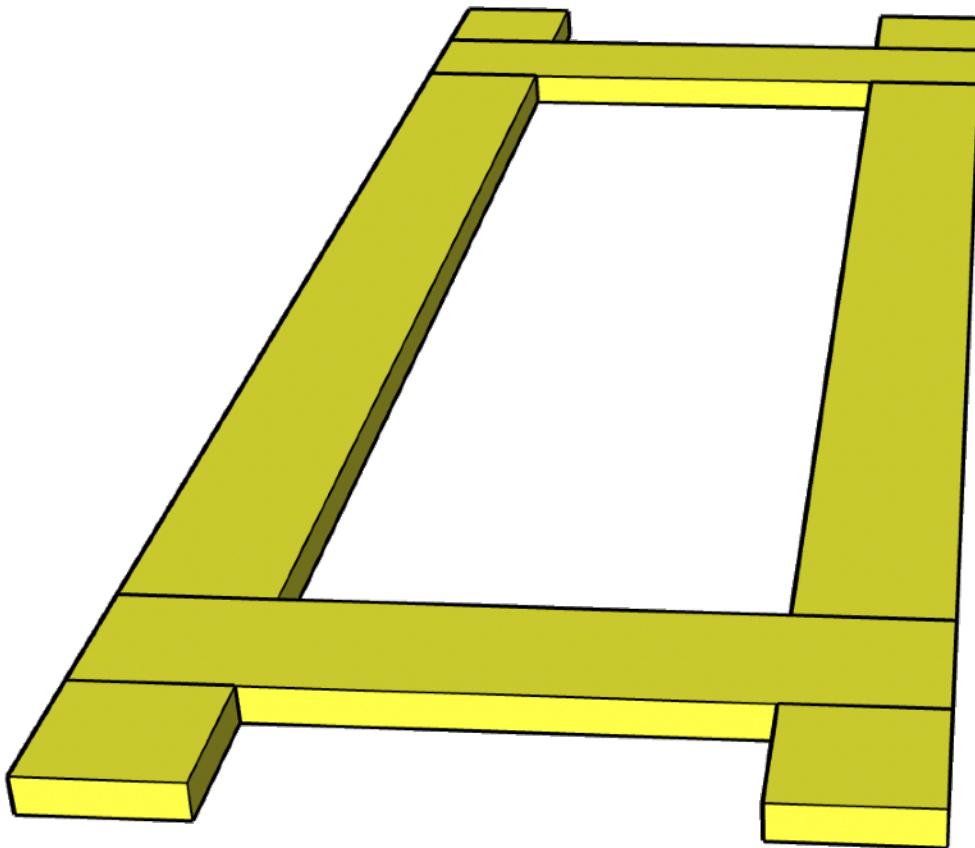
Figure 47 Long frame boards for back door sides





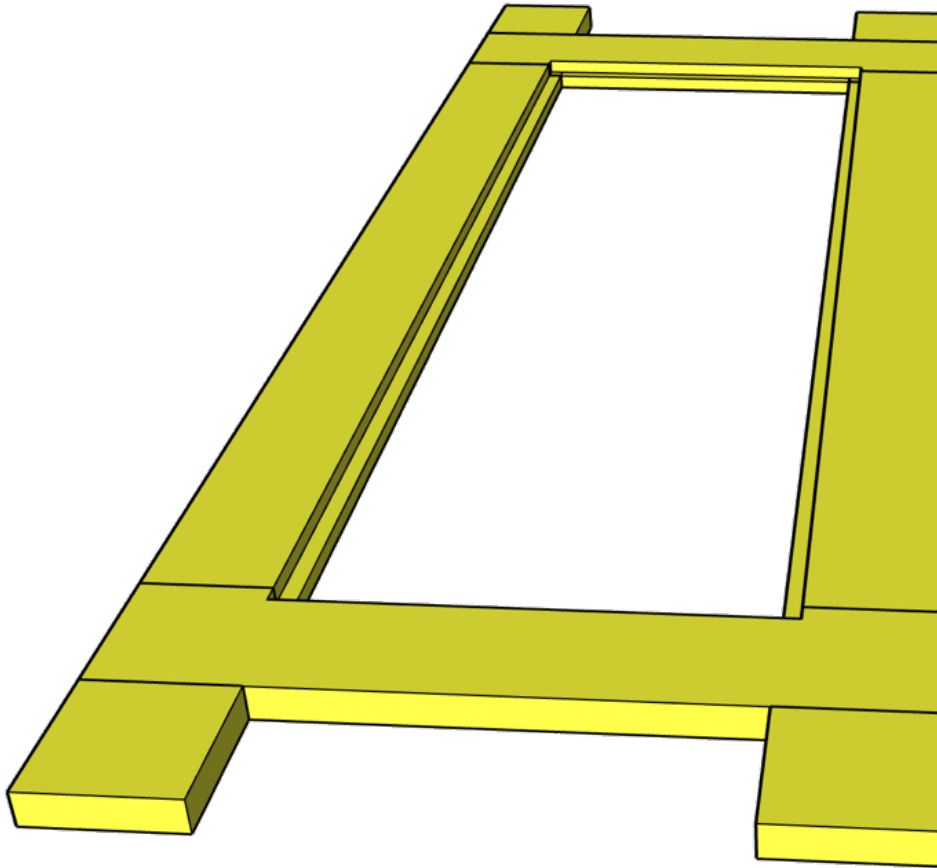
*Figure 48 Short frame boards*

- **ASSEMBLING THE FRAME:**
  - Glue the boards together to form the door frame.
  - Measure the diagonals to ensure the frame is square. If the diagonals are the same, the frame is properly aligned.



*Figure 49 Frame assembled*

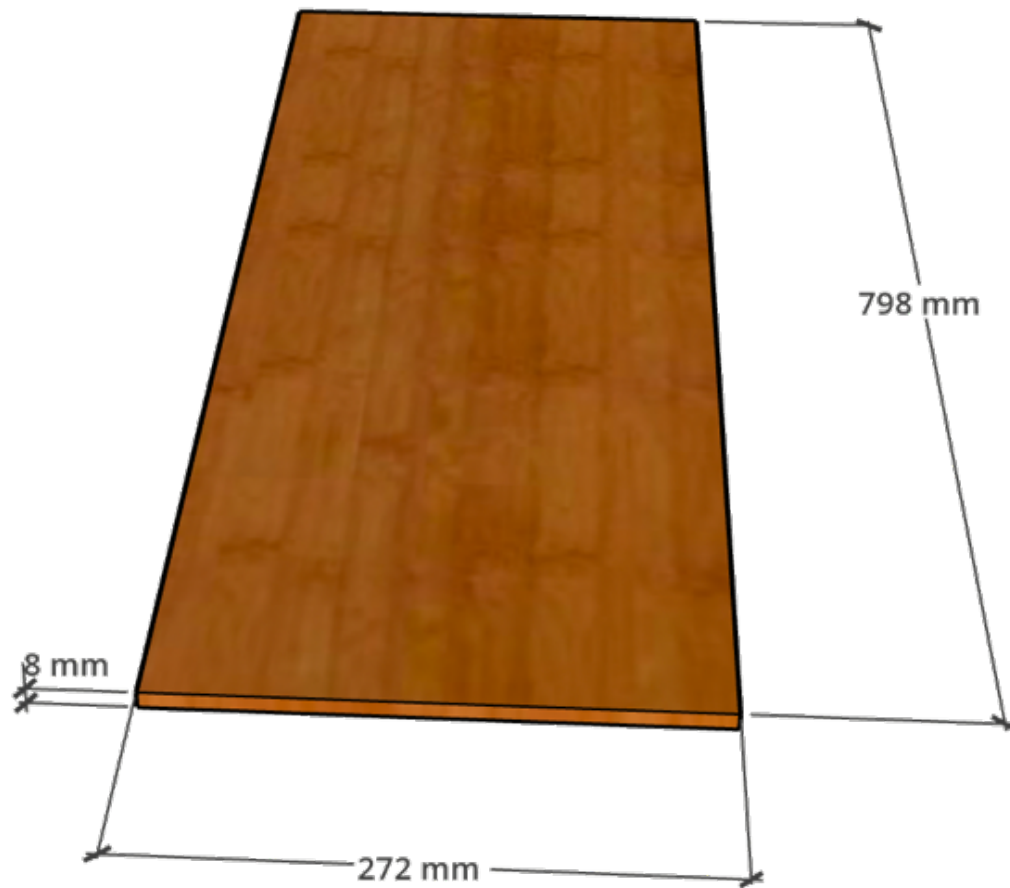
- **ROUTING THE INNER RABBET:**
  - Route a 10 mm wide and 10 mm deep rabbet around the inner edge of the frame to hold the door panel



*Figure 50 Frame with rabbet*

• **CUTTING THE DOOR PANEL:**

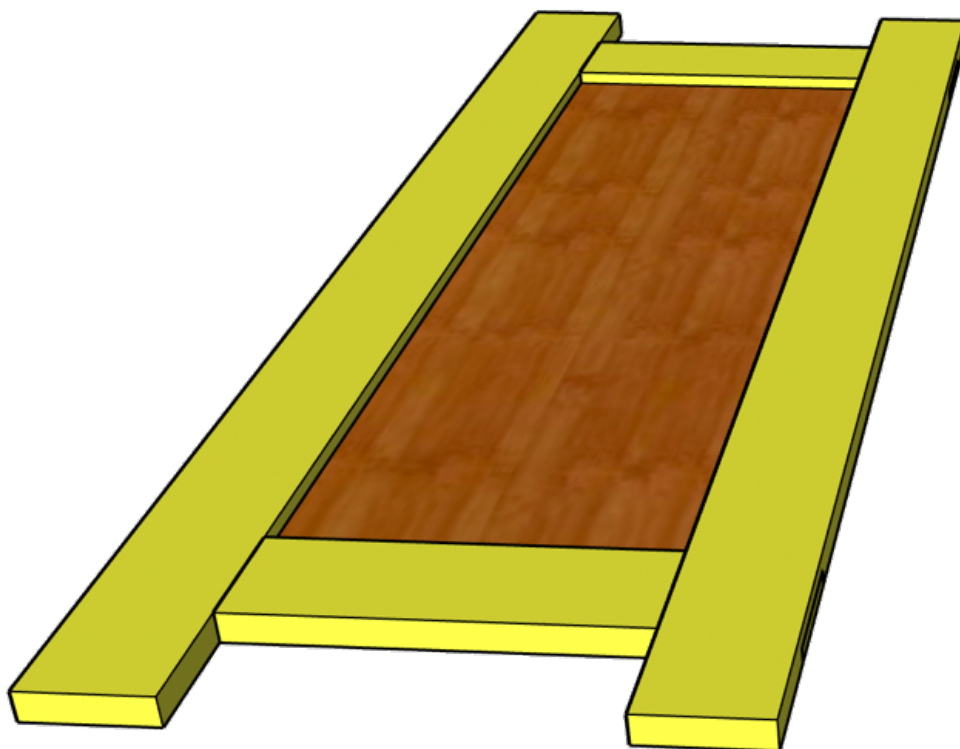
- Cut out the door panel (mirror) from 6-10 mm thick birch plywood to fit within the frame's rabbet.



*Figure 51 Plywood for mirror on the door*

• **ATTACHING THE DOOR PANEL:**

- Glue and nail the panel in place securely.

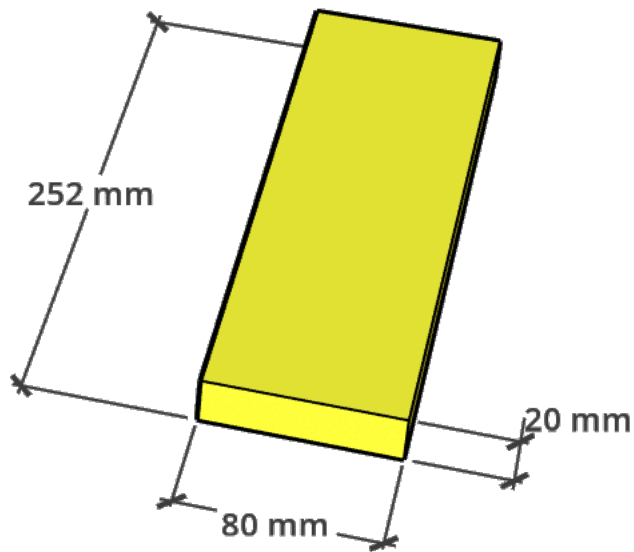


### VENTILATION OPENINGS

For ventilation, you will need two boards, each 252 mm x 80 mm x 20 mm. These boards will create adjustable openings on the door.

#### 1. Creating Ventilation Boards:

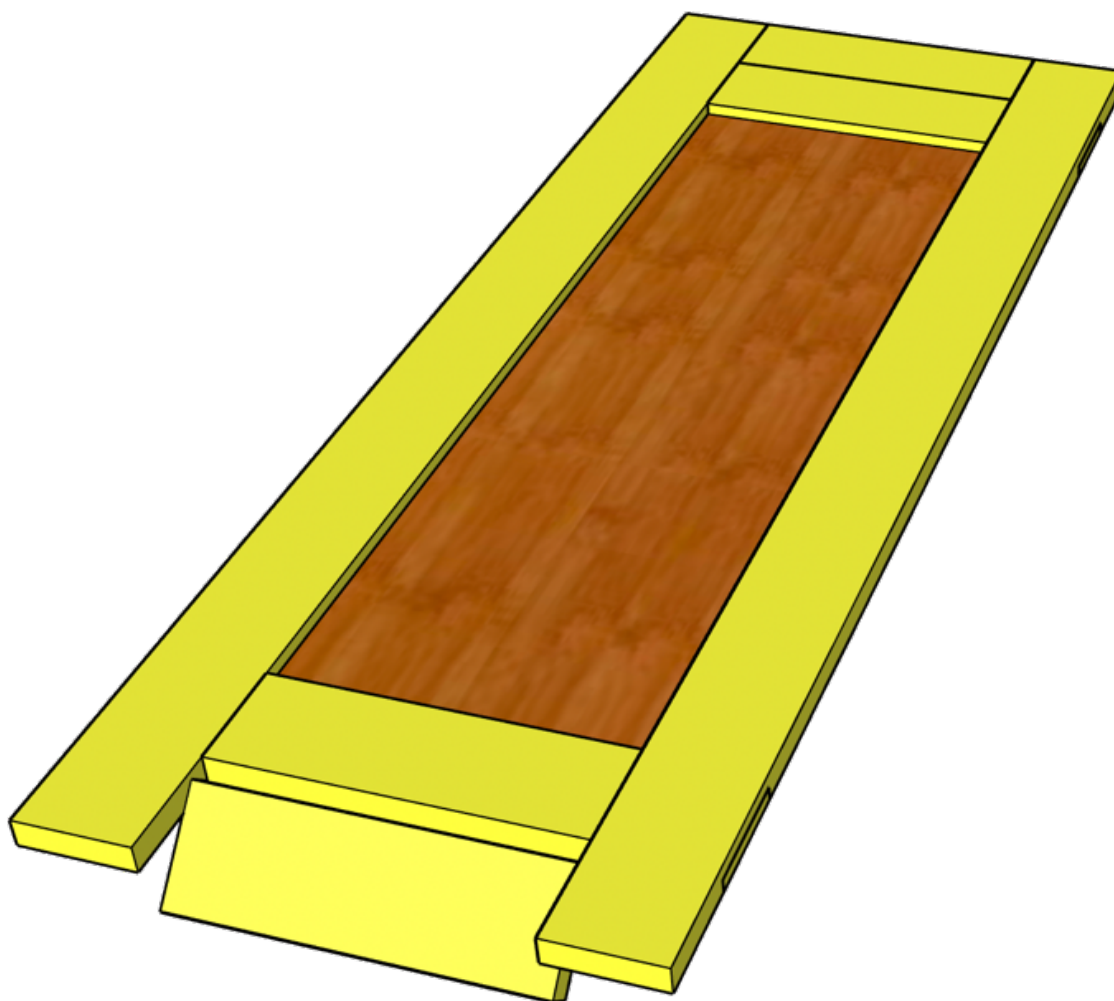
- Cut two boards to the specified dimensions for the ventilation openings.



*Figure 52 Ventilation board*

#### ATTACHING THE VENTILATION BOARDS:

- Attach the ventilation boards to the door using hinges, allowing them to open and close.



*Figure 53 Door with ventilation boards.*

#### OPTIONAL MAGNET MECHANISM:

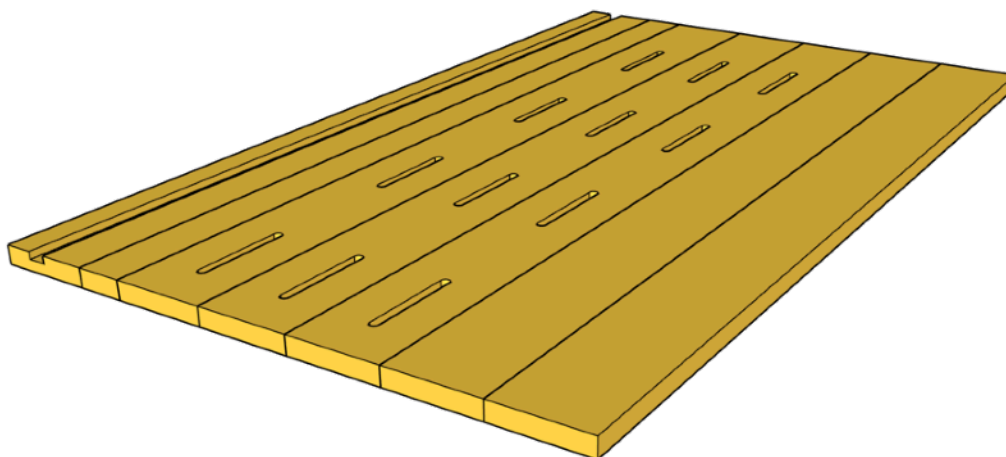
- You can add magnets to the inside of the door to allow the lower ventilation board to open and close. The upper ventilation board will remain open by gravity.

#### FINAL ASSEMBLY

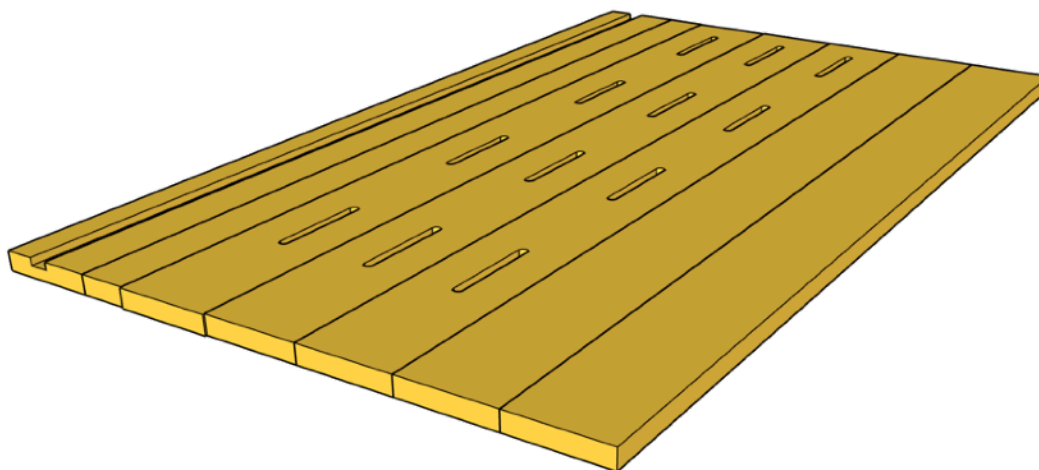
- Once the back door is assembled, install it onto the hive. Ensure the ventilation boards are correctly aligned and functional.

## Assembly

**Sides:** Assemble the sides using the provided boards. The 50 mm boards should be placed as the second board to correctly align the rod slots.

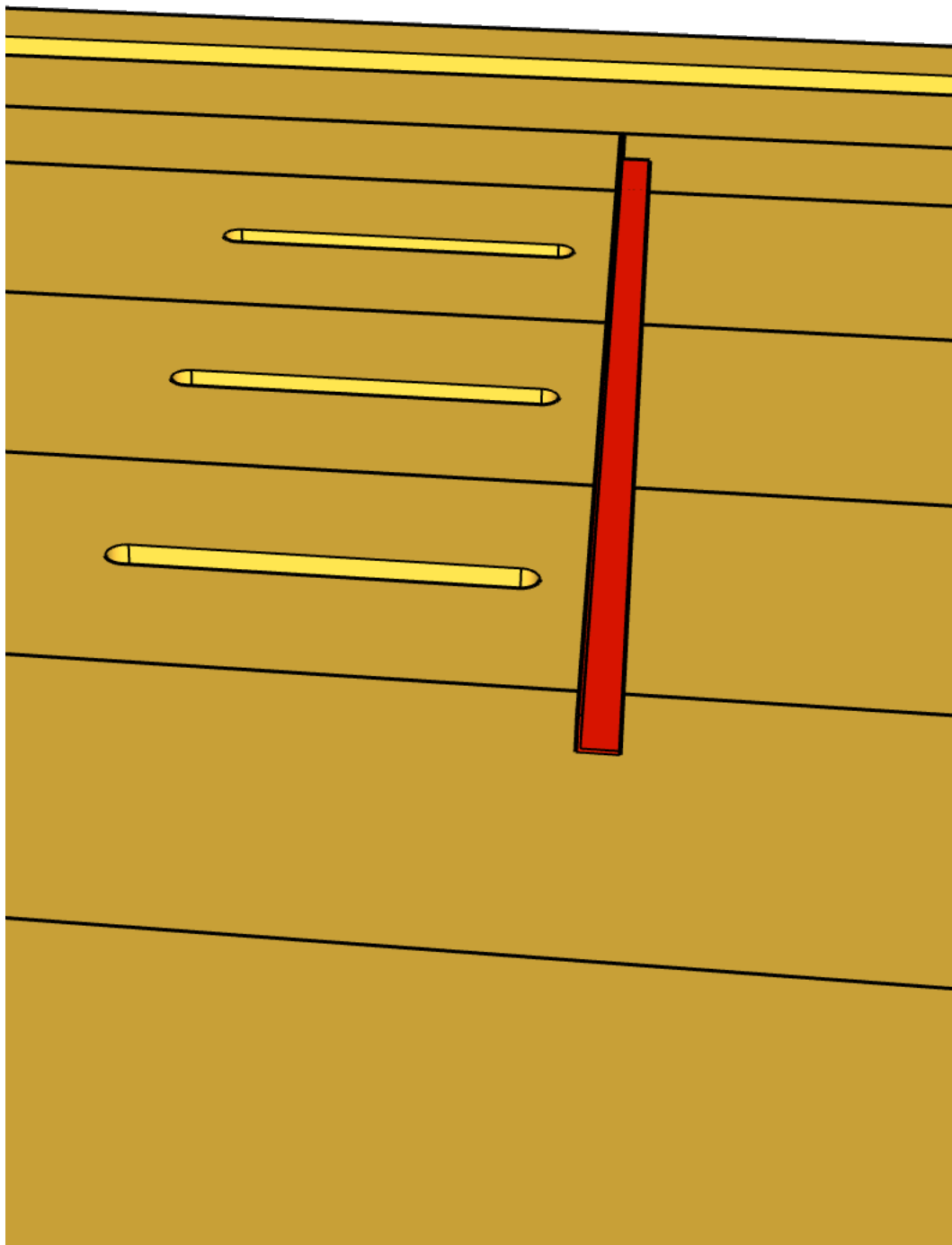


*Figure 54 The first side*



*Figure 55 The second side, Note that it is mirrored compared to the first side*

On both side panels, install shelves using angle irons, positioning them 12 mm below the rod rest for the queen excluders and false queen excluders. These shelves should not be added to the bottom row.

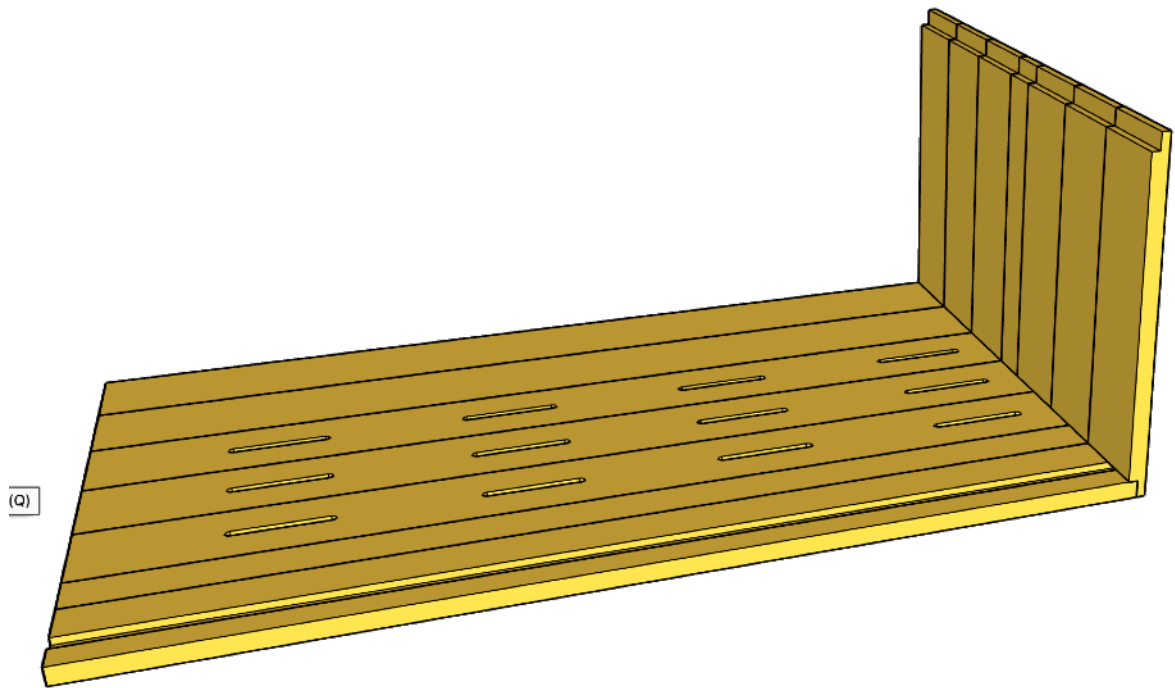


*Figure 56 Side with shelf*

ADDING THE BOTTOM



1. Attach the bottom panel using nails. Ensure it is securely fastened to prevent any gaps.
2. Check that the panel is level and properly aligned with the sides.

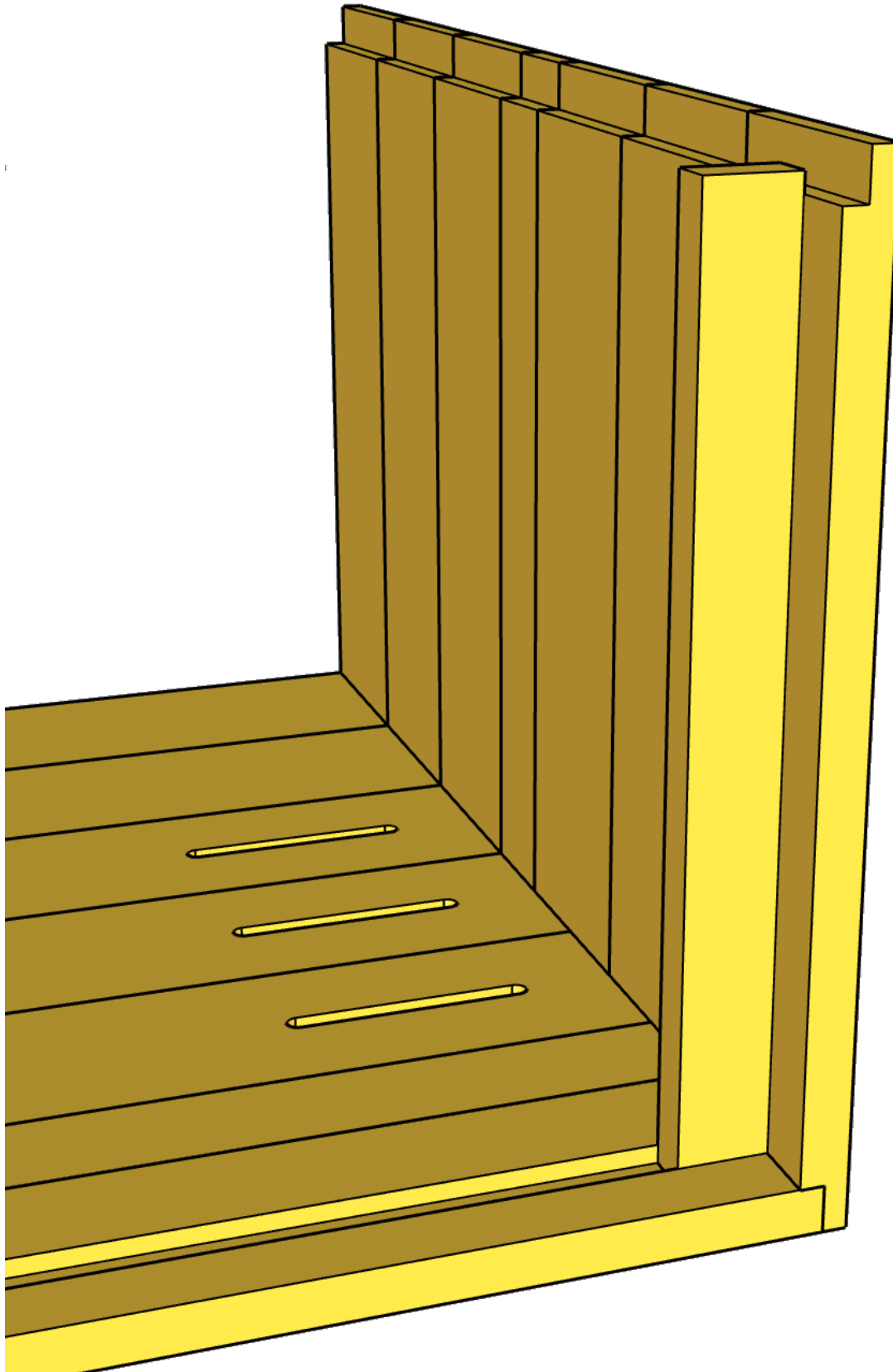


*Figure 57 Bottom fastened*

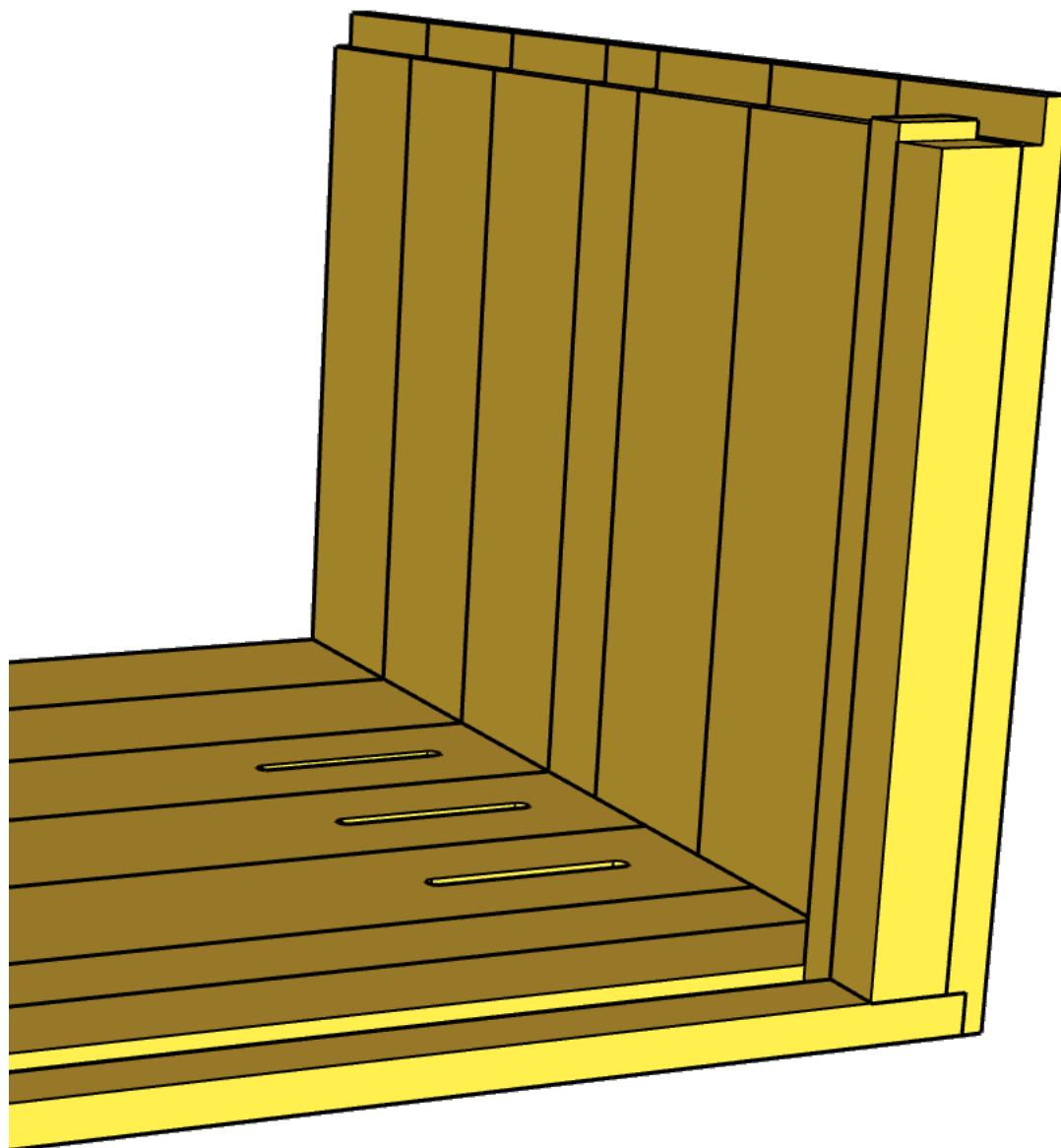
#### INNER WALL ASSEMBLY

- Start by adding a 48 mm wide board to the inner slot and secure it with a few nails from the bottom.

- Continue adding inner wall boards, using 12 mm wooden spacers for bee entrances.



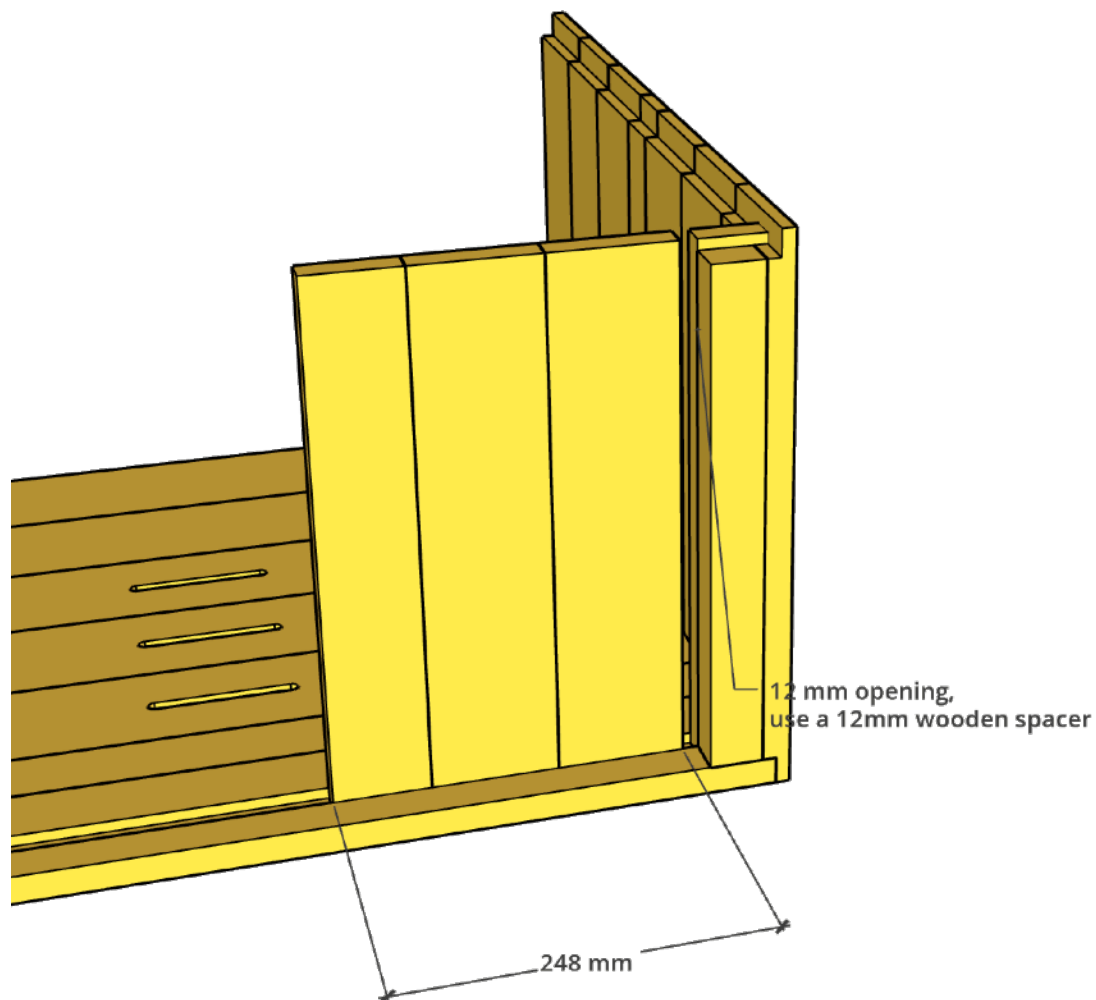
*Figure 58 First inner wall board*



*Figure 59 In between board for the entrance.*

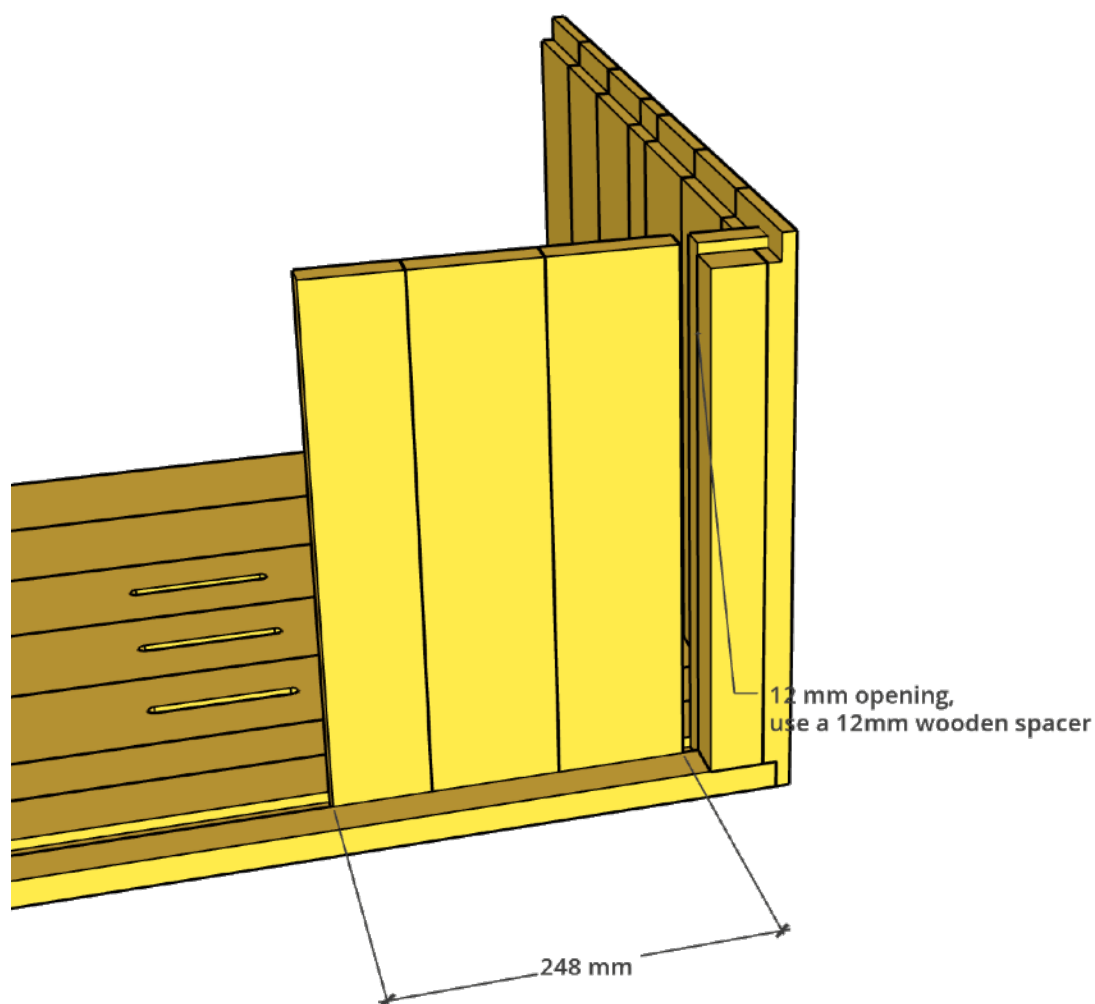
Add a 12 mm wooden spacer for the bee entrance before adding the next inner wall board. You can cut a 12 mm strip from a 20 mm thick board and shorten it to about 8 mm or slightly longer. The bees won't mind if the entrance length is 372 mm or 360 mm, but your sense of perfection might!

Continue adding inner wall boards up to the next entrance, which should be about 2 mm below the alignment of the second level's rod slots.



*Figure 60 More inner wall with 12mm bee entrance*

Add a 12 mm wooden spacer for the bee entrance before adding the next inner wall board. Then, continue adding inner wall boards up to the next entrance, approximately 2 mm below the second level's rod slots.



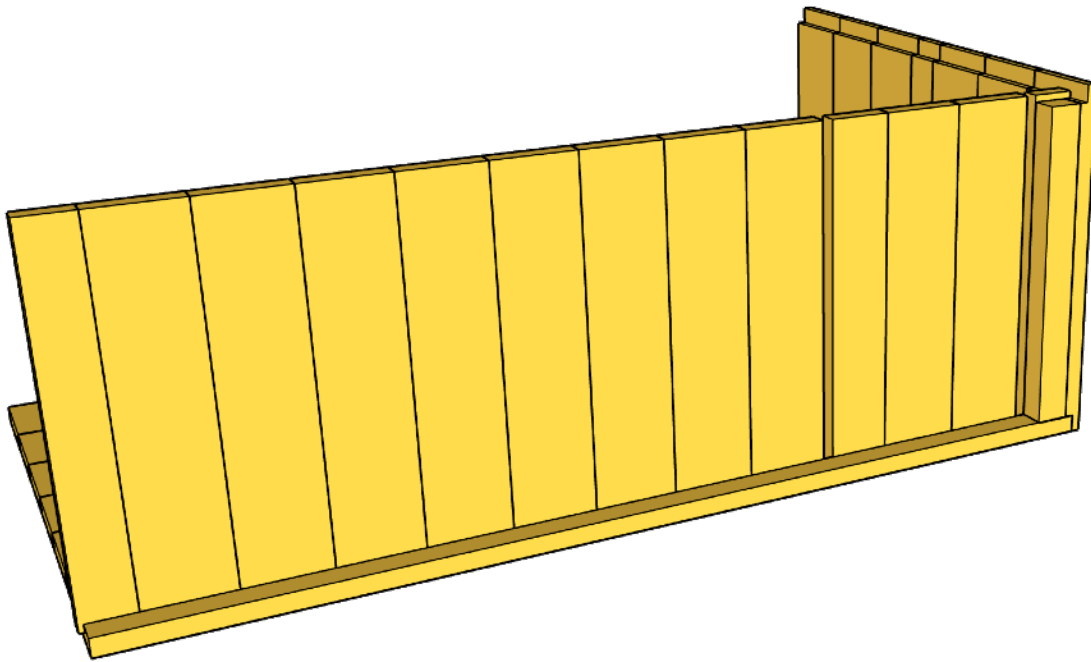
*Figure 61 Add more inner wall boards*

Add another 12 mm spacer and the rest of the inner wall boards.

Note that you do not need to fasten the inner wall boards, but place a nail on the board just above the entrances.

This can be done when the second wall and roof are in place if it is easier.

The last inner board should be cut 5 mm above the side board to fit in the roof rabet. Do not make it fit the full 10 mm deep rabet, as wood moves with moisture.



*Figure 62 The rest of the inner wall*

#### Add the Second side wall

Once you've added all the inner wall boards, proceed to add the second side wall. You may face some difficulty fitting the inner wall boards into the rabbet, but it should work after some tries. Secure the second side wall with nails at the bottom and one nail on the inner wall boards, just above the entrances.

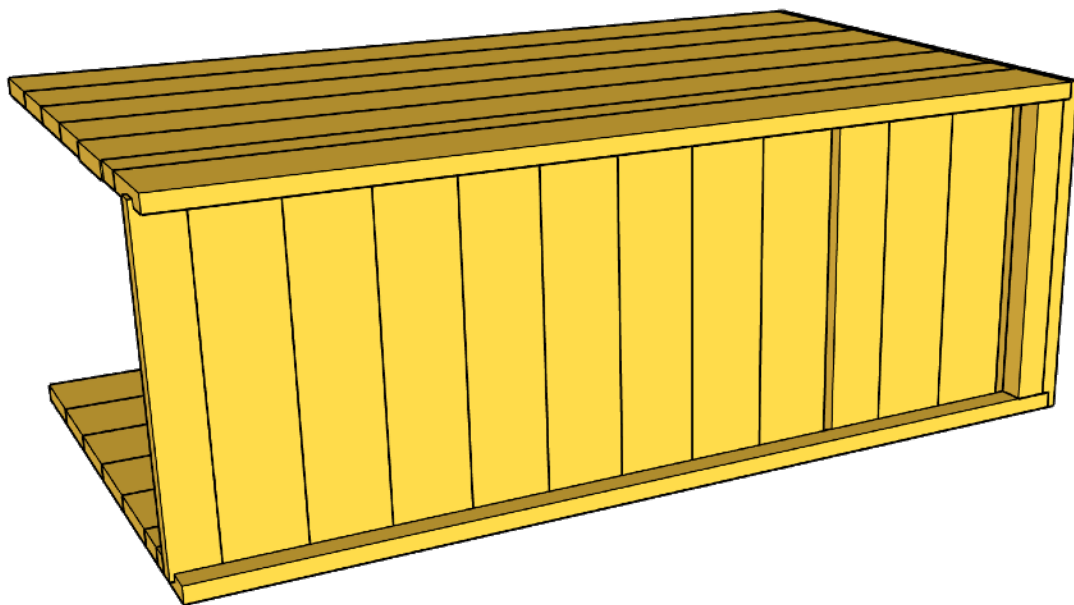


Figure 63 Second side wall added

**ADD ROOF AND ISOLATION BOARDS**

Add the roof and the boards that will hold the insulation in place. These boards will also serve as the bee entrances.

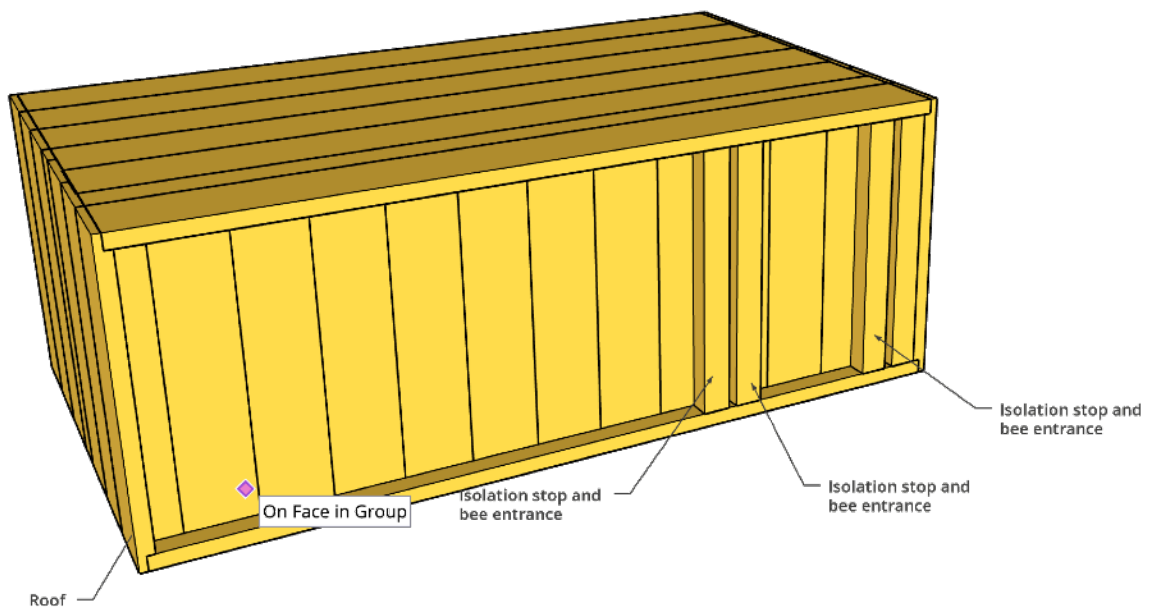
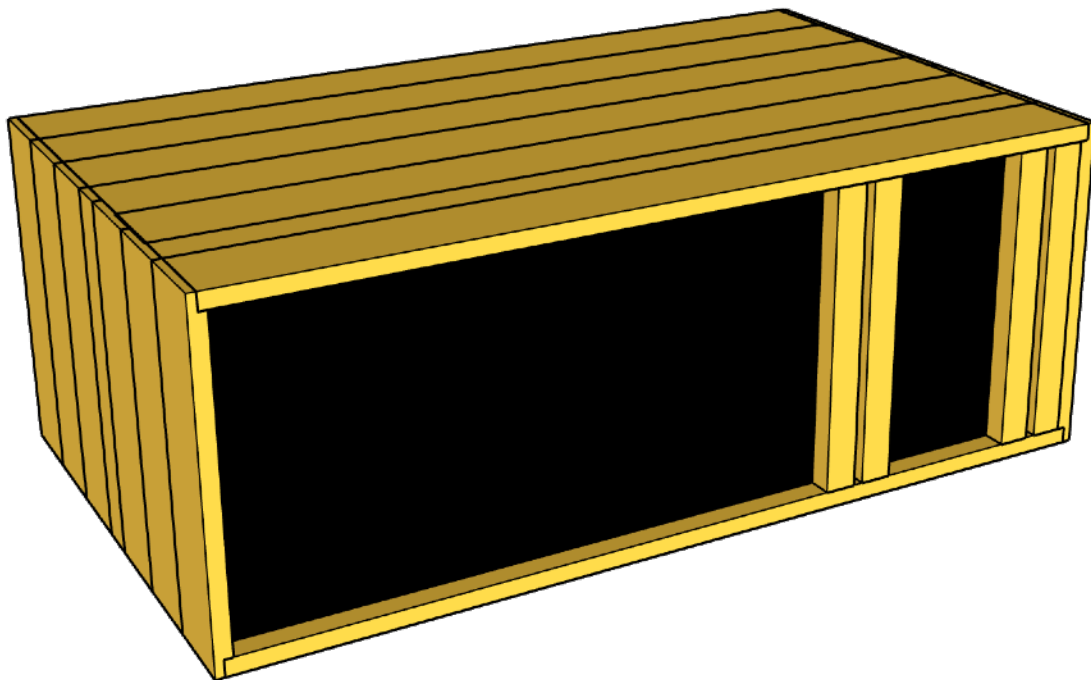


Figure 64 Roof and bee entrance.

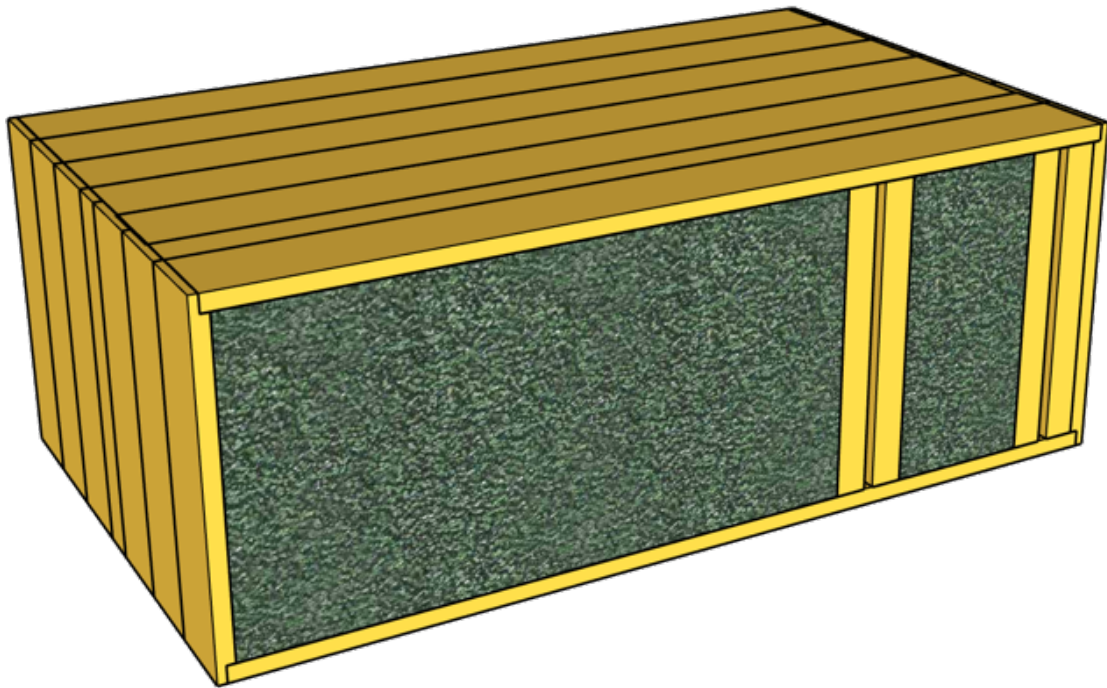
**ADD ISOLATION**

Once the inner wall is complete, add wind protection (such as wind paper) and insulation (stone wool or similar).



*Figure 65 Added wind paper*

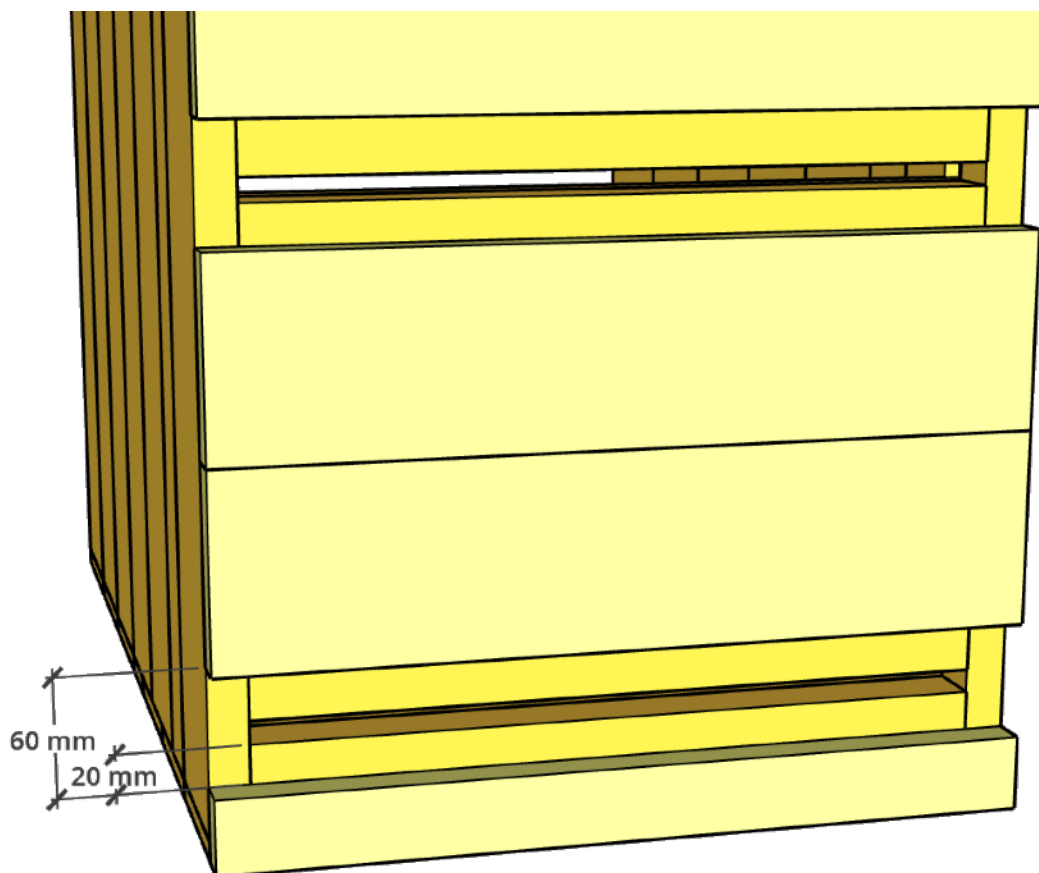




*Figure 66 Stone Wool isolation*

#### ADD FRONT WALL

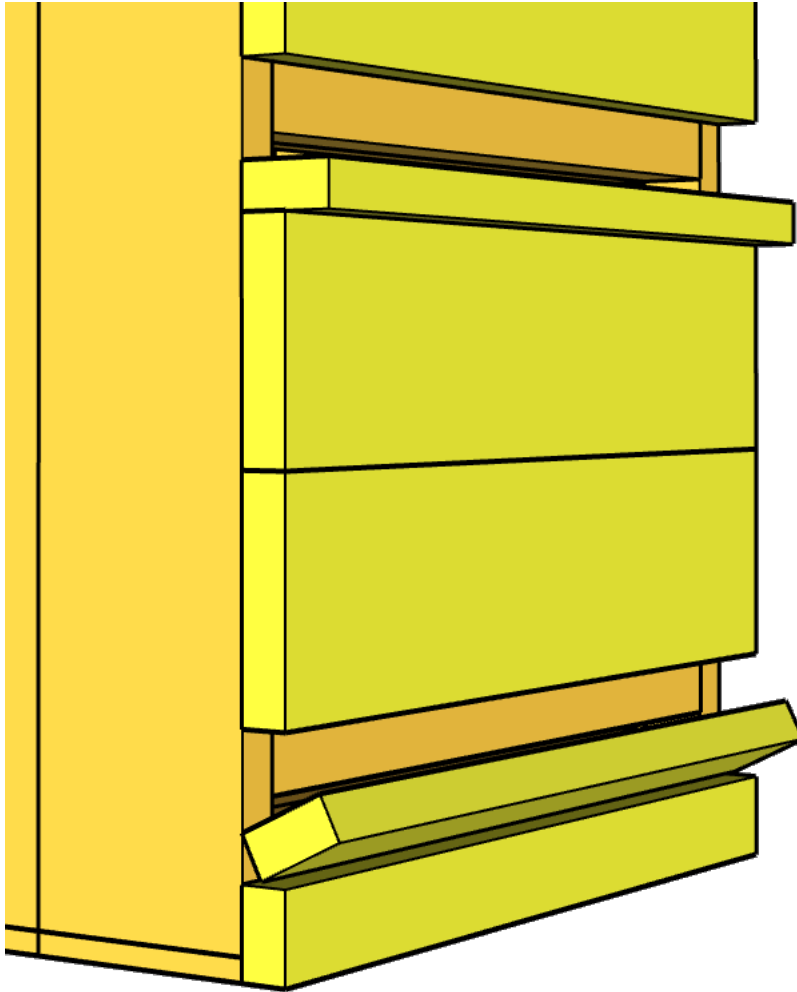
Attach the front wall boards, leaving a 20 mm space below the front entrance and a total of 60 mm.



*Figure 67 Front wall boards*

#### ADD CLOSABLE ENTRANCE

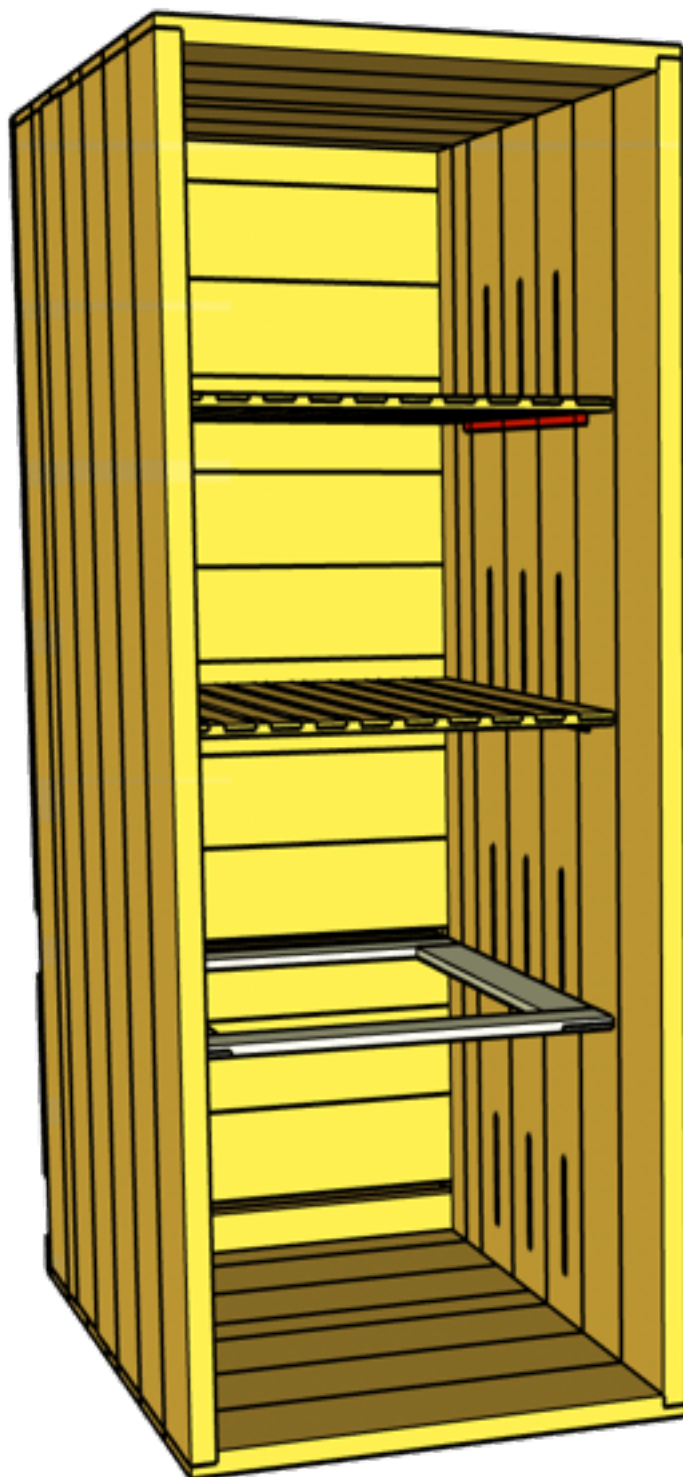
Use a 412 mm x 40 mm x 20 mm board for the closable entrances.  
Attach them using hinges.



*Figure 68 Closable entrances*

Add a locking mechanism to secure the entrance during transportation. You can use either a metal lock or a wooden lock that rotates to lock the entrance.

- Place the queen excluders on the shelves.

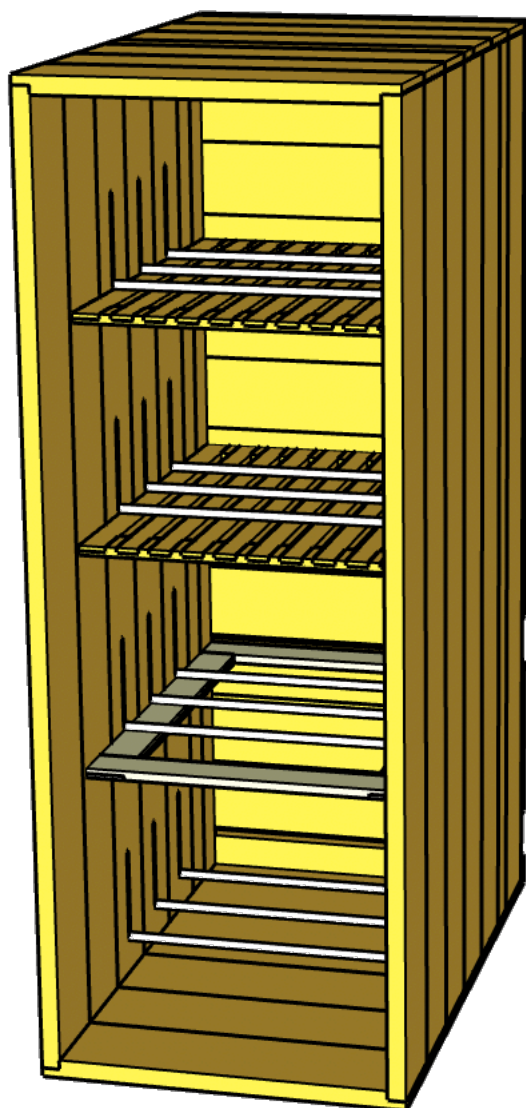


*Figure 69 Box with queen excluder and divider*

Cut the rods to the correct length. If you made the slots for the rods 8 mm deep, the rods should be 388 mm long. Adjust the length slightly if

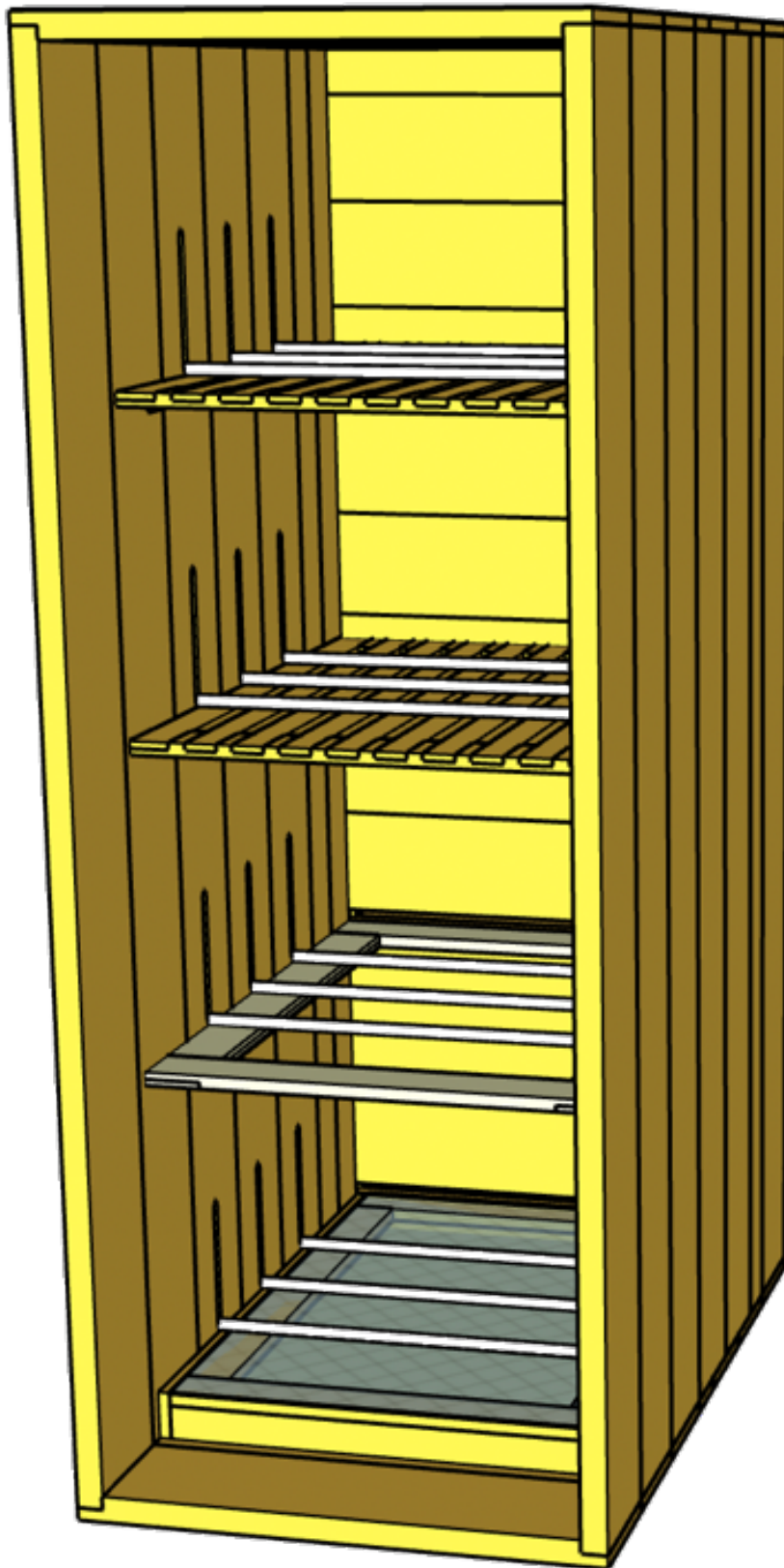
necessary, depending on the depth of your slots. The main thing is to ensure that the rods are secure and cannot fall out on their own.

Insert the rods into place, ensuring they are secure and cannot fall out by themselves.



*Figure 70 Rods added, check that they cant fall of by them selfs*

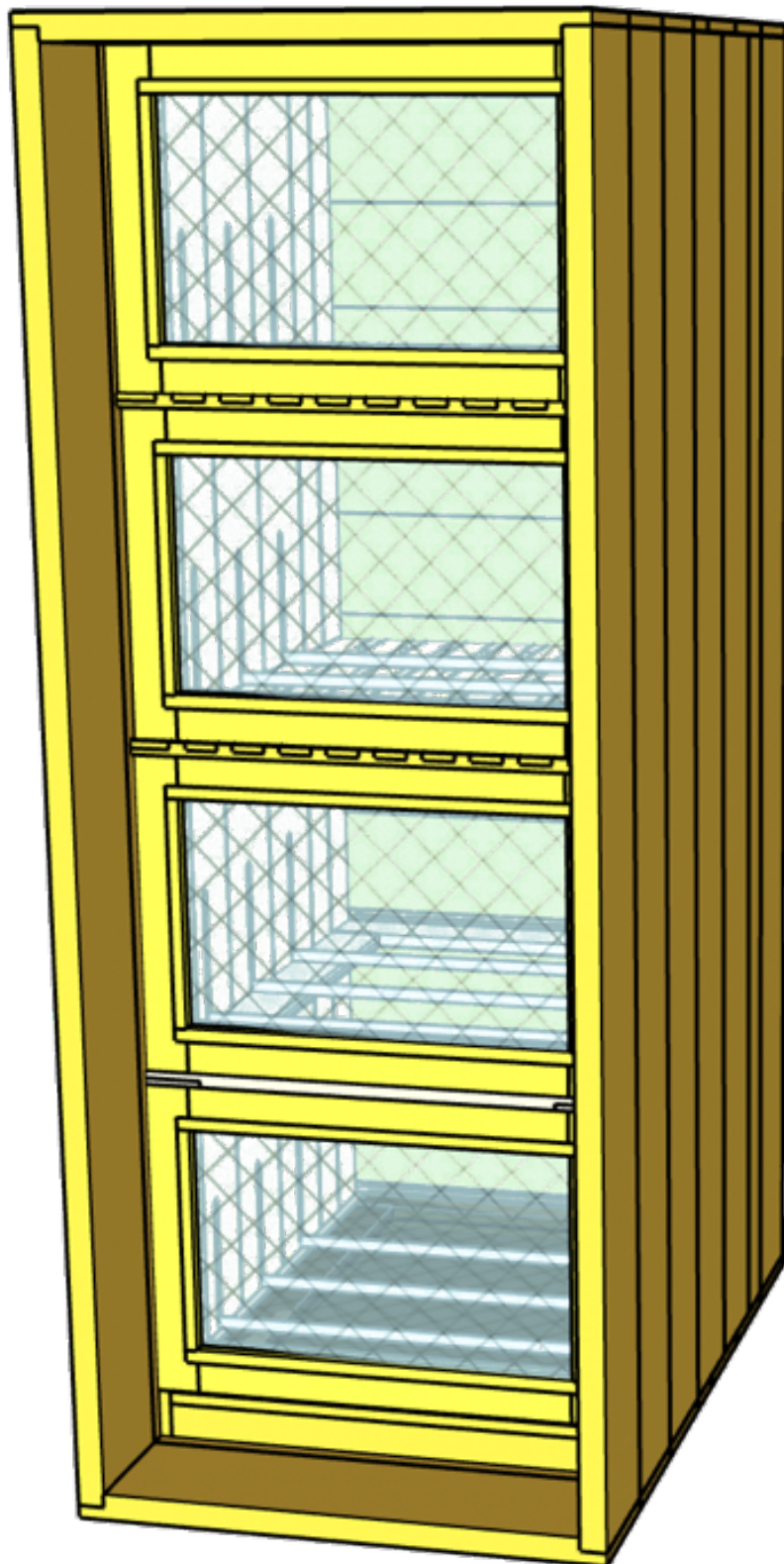
Add the varroa floor



*Figure 71 Varroa floor added*

Add two bee frame spacers on the inner wall per level, along with corresponding spacers on the inner doors. Add the frames and dry-fit the inner doors. If the doors fit too tightly, you can plane down 1-2 mm on the sides to ensure easier handling later.

Mark where the door locks should be positioned.



*Figure 72 Inner doors added.*



For the locks, you can use hatches or rods.

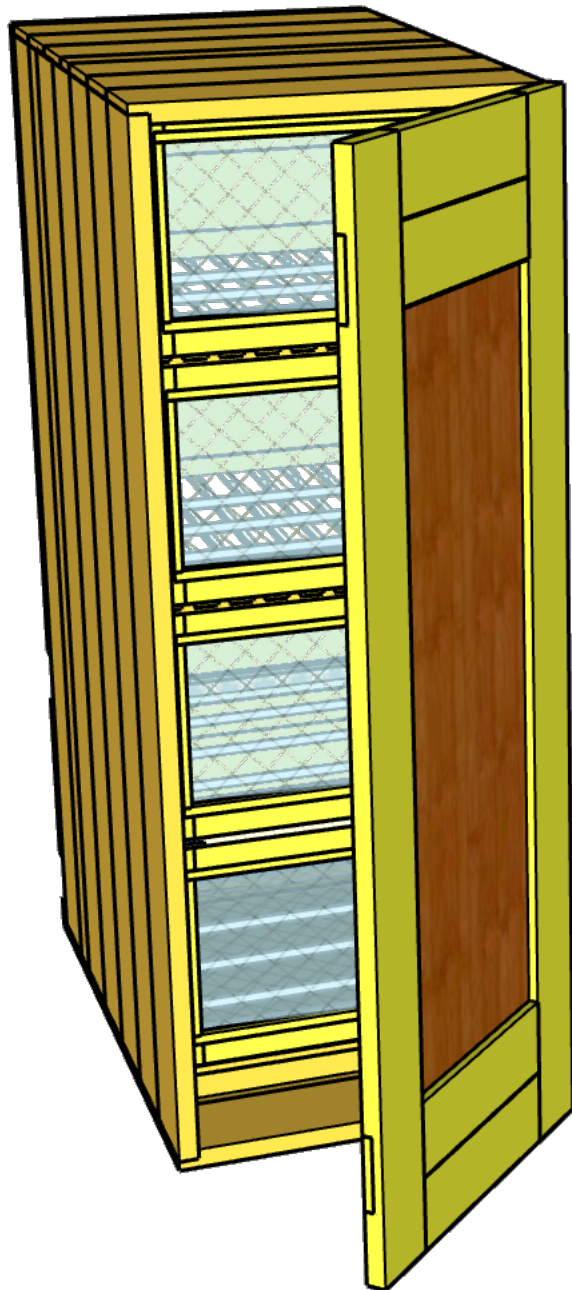
Add the locks and assembly the inner doors again.

Adding the Outer Door

Lastly, add the outer door using **lift-off hinges**.



These hinges allow you to remove the door easily without the need to unscrew anything, making it more convenient for inspections or maintenance. Once the hinges are attached, ensure the door is aligned properly and test the lift-off functionality to ensure it operates smoothly.



*Figure 73 Finished hive*

And the hive is finished.